

MAISON



Recycled Field

Porcelain



1/2" x 1/2" Recycled Field

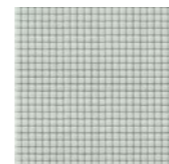

Salt - matte

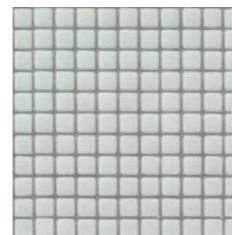

Salt - polished

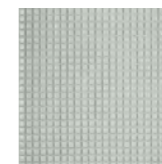

Salt - iridescent

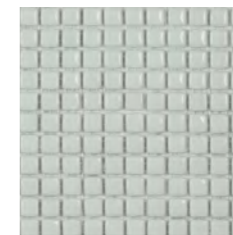

Snow - matte



Snow - polished



Snow - iridescent



Ice - matte

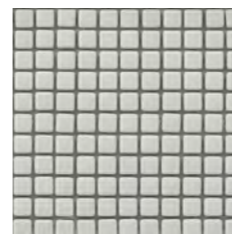

Ice - polished

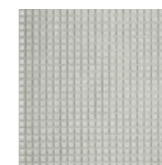

Ice - iridescent

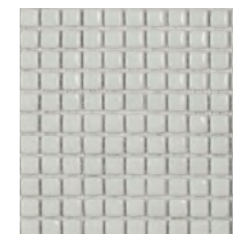

Frost - matte

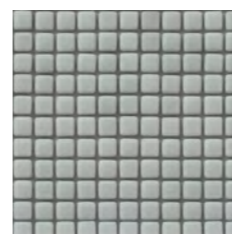

Frost - polished

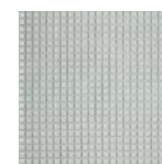

Frost - iridescent



Unit: 11 12/16" x 11 12/16"
 Unit Yield: 0.96 sqft
 Yield per box: 9.56 sqft

Piece size: Square 1/2"x 1/2"
 Sheets per box: 10
 Pallet Yield: 774.26 sqft

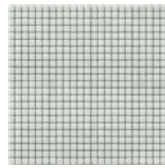

Cloud - matte



Cloud - polished

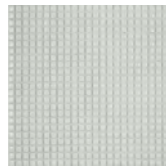

Cloud - iridescent

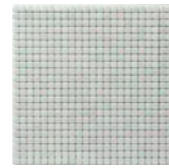
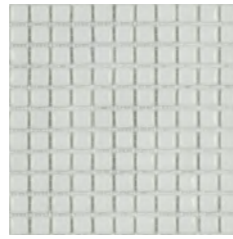

Iron - matte



Iron - polished



Iron - iridescent

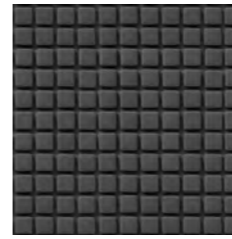
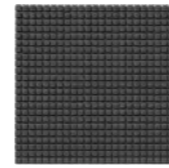

Pumice - matte



Pumice - polished

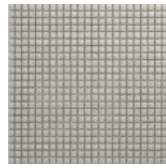

Pumice - iridescent

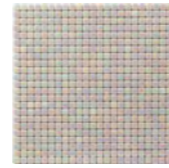

Flint - matte

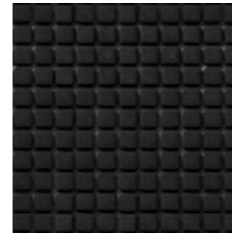

Flint - polished

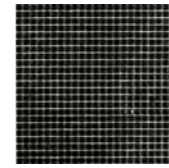

Flint - iridescent

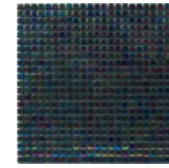
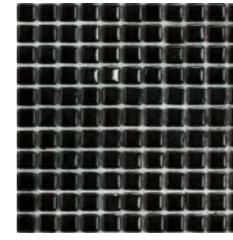

Smoke - matte

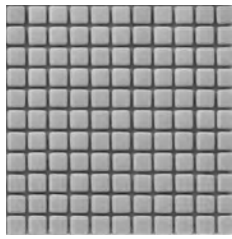

Smoke - polished

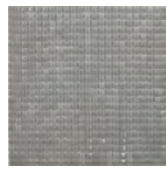

Smoke - iridescent

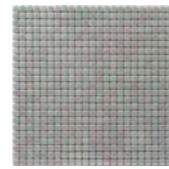

Twilight - matte

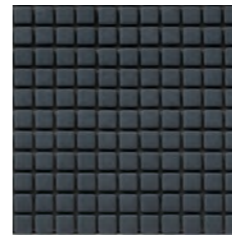

Twilight - polished

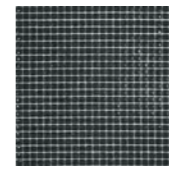

Twilight - iridescent

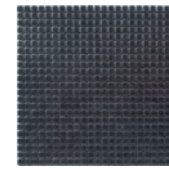
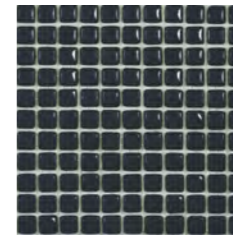

Charcoal - matte



Charcoal - polished

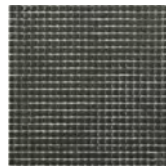

Charcoal - iridescent

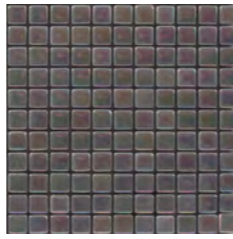
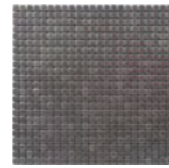

Shadow - matte

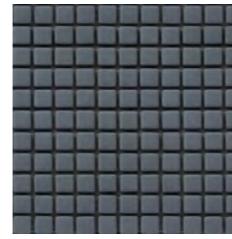

Shadow - polished

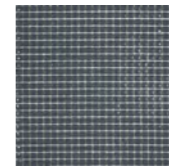

Shadow - iridescent

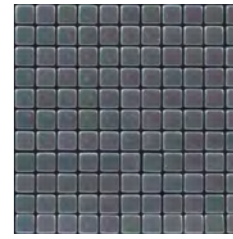
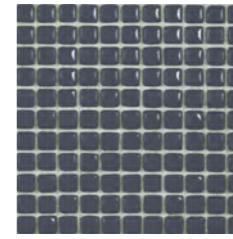



Grit matte

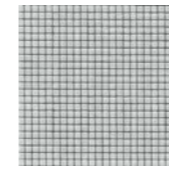

Mist - matte

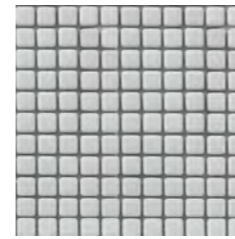

Mist - polished

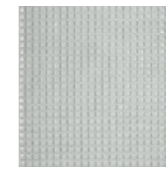

Mist - iridescent

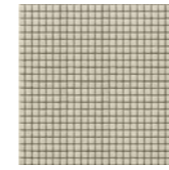
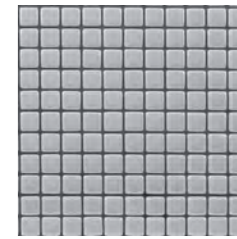
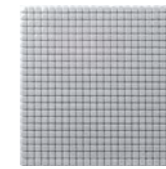

Porcelain - matte

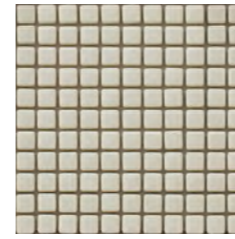

Porcelain - polished

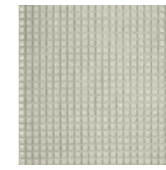

Porcelain - iridescent

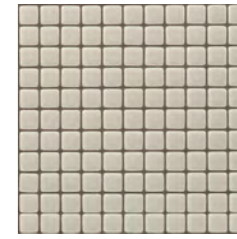
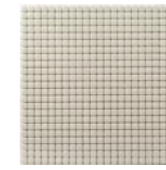

Porcelain matte

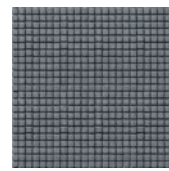
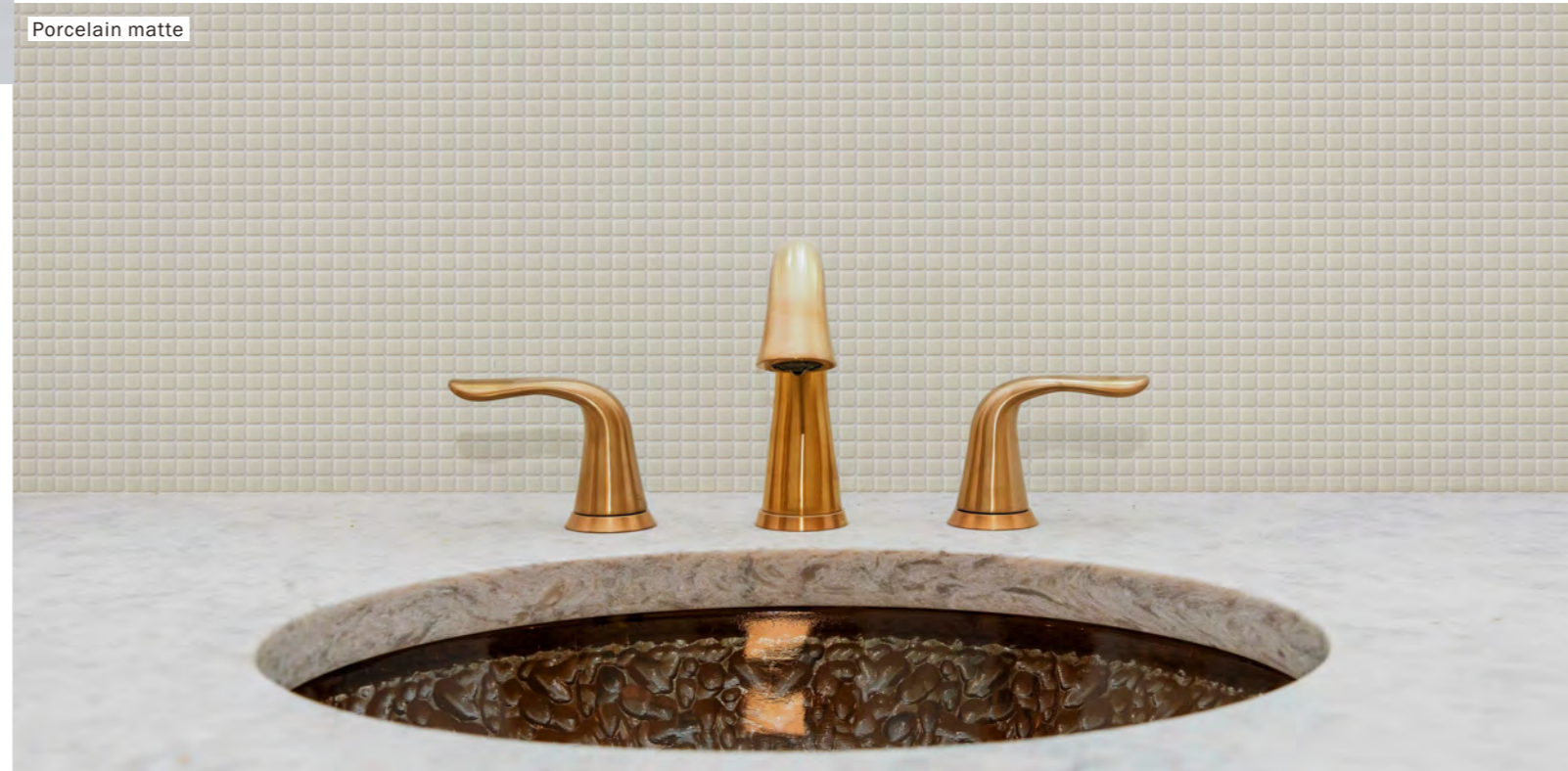

Grit - matte

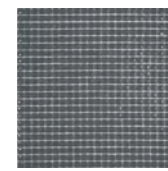
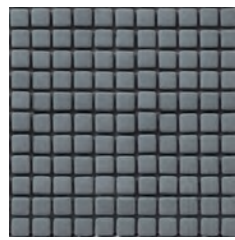

Grit - polished

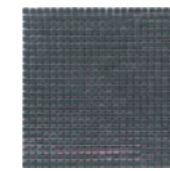
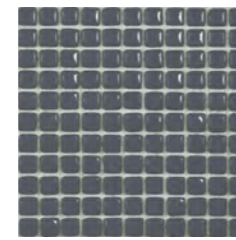

Grit - iridescent

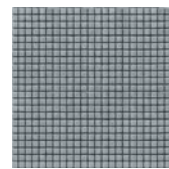
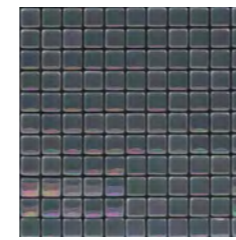

Steel - matte

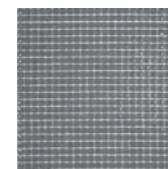
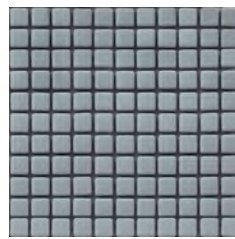

Steel - polished

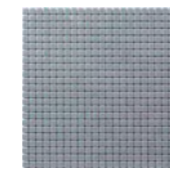
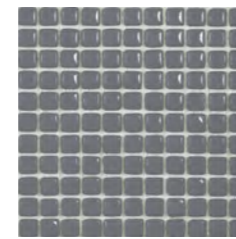

Steel - iridescent

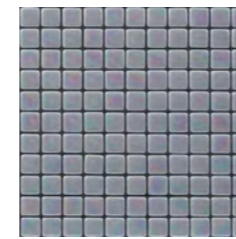

Unit: 11 12/16" x 11 12/16"
Unit Yield: 0.96 sqft
Yield per box: 9.56 sqft

Piece size: Square 1/2" x 1/2"
Sheets per box: 10
Pallet Yield: 774.26 sqft

Unit: 11 12/16" x 11 12/16"
Unit Yield: 0.96 sqft
Yield per box: 9.56 sqft

Piece size: Square 1/2" x 1/2"
Sheets per box: 10
Pallet Yield: 774.26 sqft

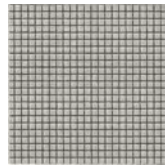

Ash - matte



Ash - polished

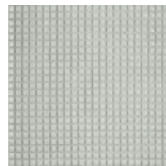

Ash - iridescent

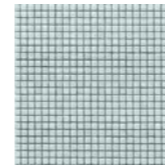

Arctic - matte

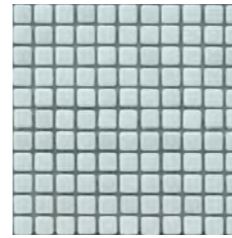

Arctic - polished

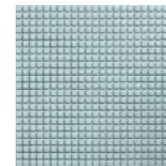

Arctic - iridescent

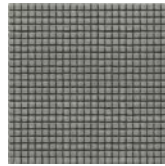
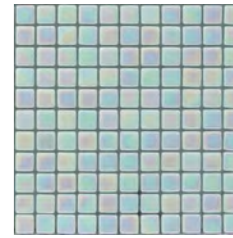
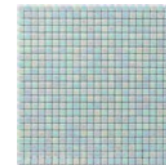

Coin - matte

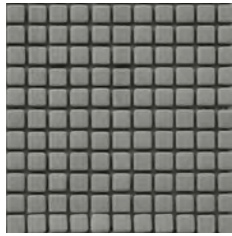

Coin - polished

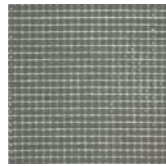

Coin - iridescent

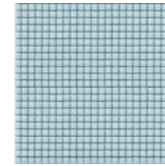
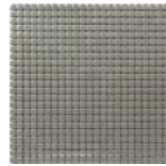

Glacier - matte

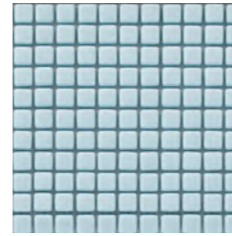

Glacier - polished

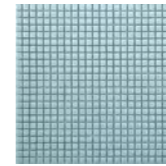

Glacier - iridescent

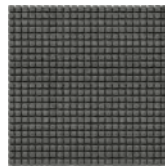
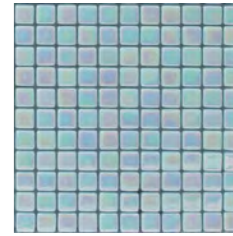
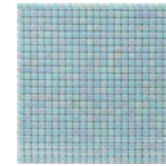

Graphite - matte

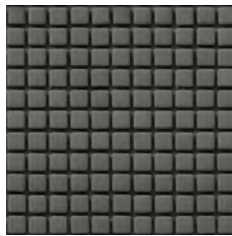

Graphite - polished

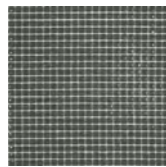

Graphite - iridescent

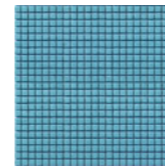
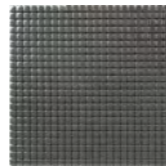

Atmosphere - matte

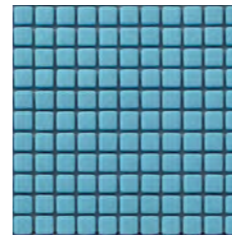

Atmosphere - polished

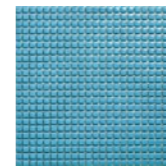

Atmosphere - iridescent

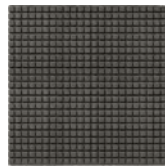
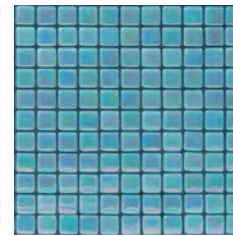
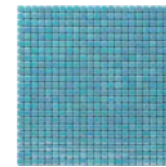

Lead - matte



Lead - polished

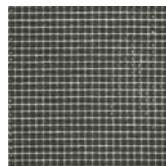

Lead - iridescent

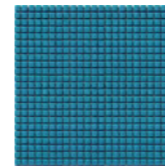
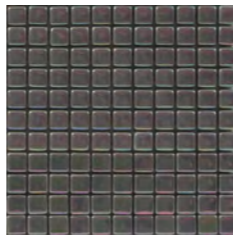
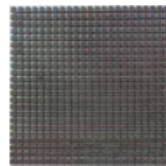

Shore - matte

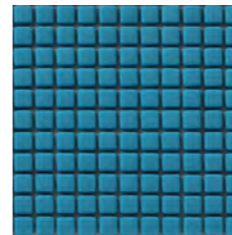

Shore - polished

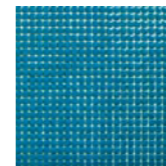

Shore - iridescent

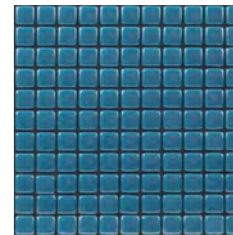
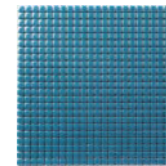



Dusk matte

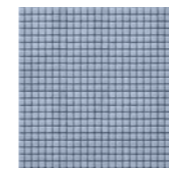

Aegean - matte

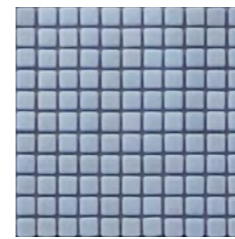

Aegean - polished

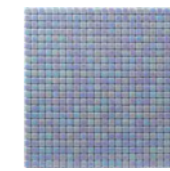
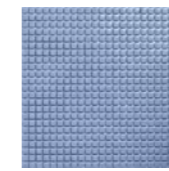

Aegean - iridescent

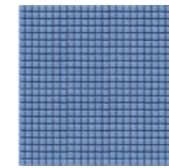
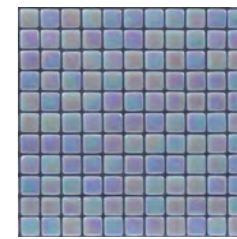

Lapis - matte

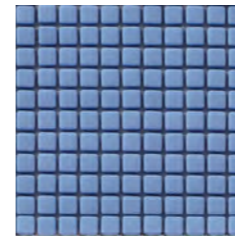

Lapis - polished

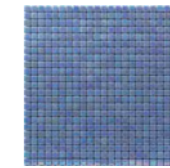
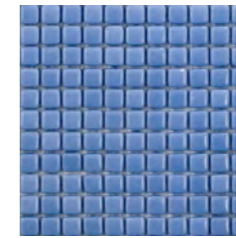
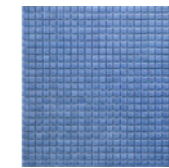

Lapis - iridescent

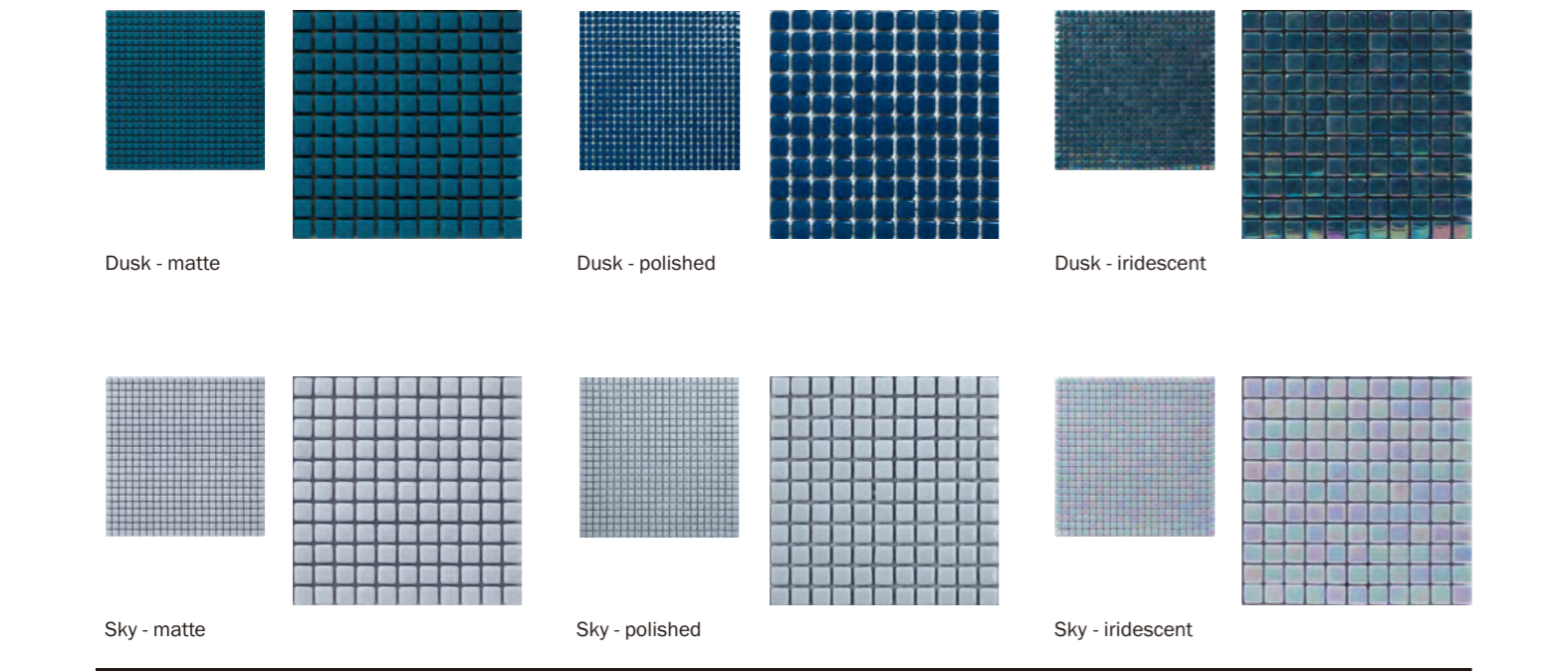
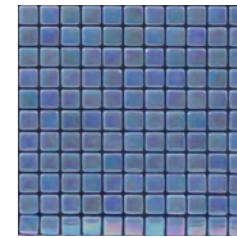

Dusk - matte

Dusk - polished

Dusk - iridescent

Sky - matte

Sky - polished

Sky - iridescent

Lapis matte

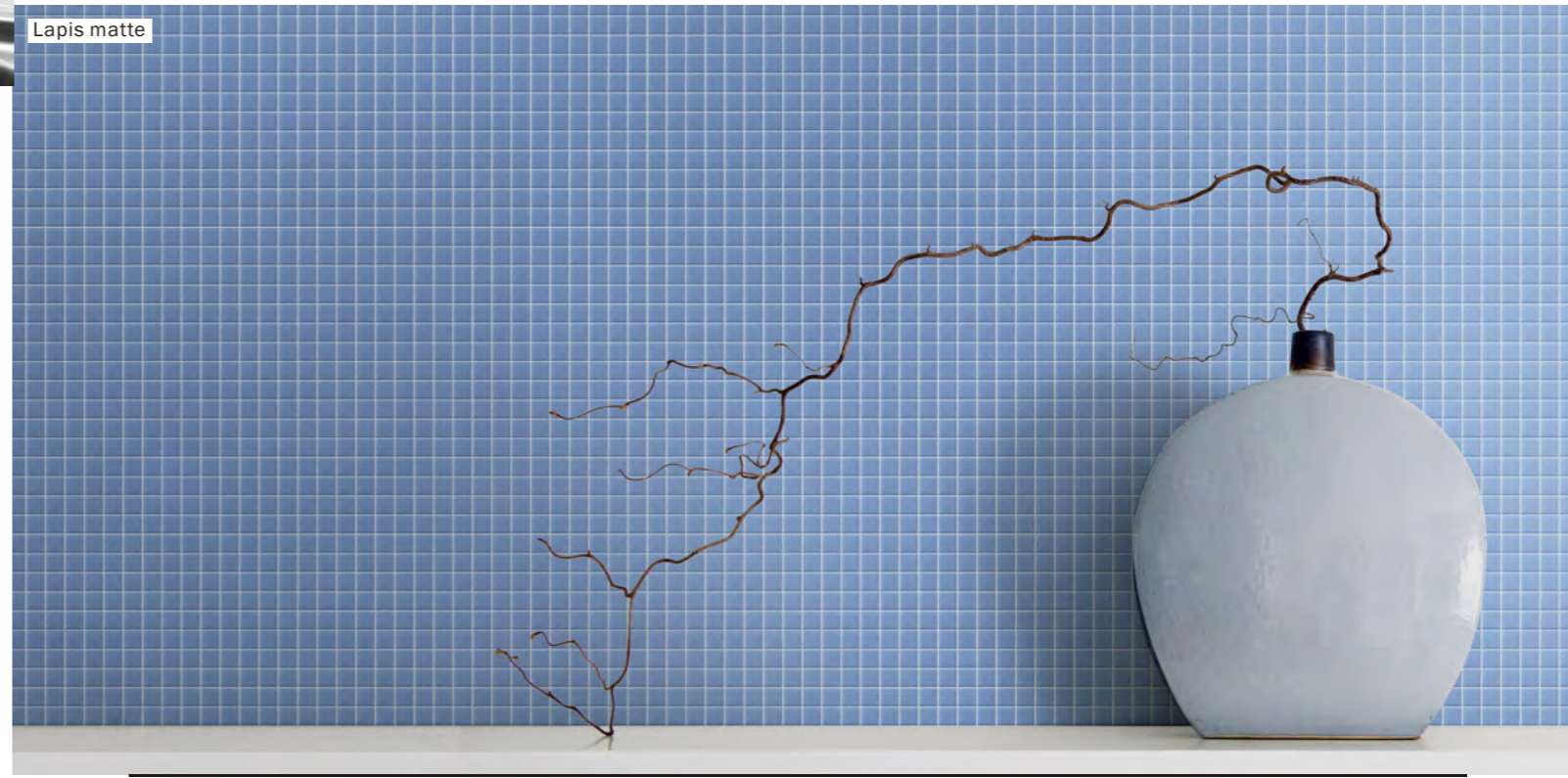

Unit: 11 12/16" x 11 12/16"
 Unit Yield: 0.96 sqft
 Yield per box: 9.56 sqft

Piece size: Square 1/2"x 1/2"
 Sheets per box: 10
 Pallet Yield: 774.26 sqft

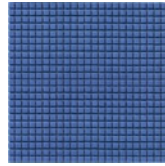

Azure - matte

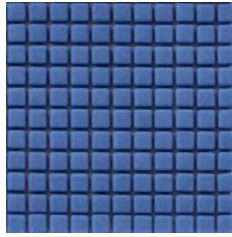

Azure - polished

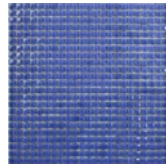

Azure - iridescent

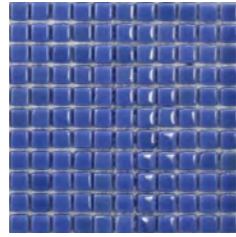

Slate - matte



Slate - polished

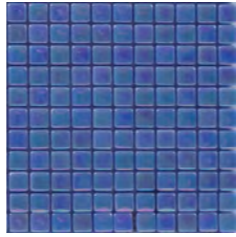

Slate - iridescent

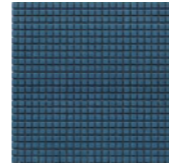

Denim - matte

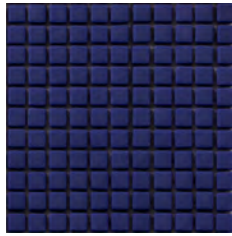

Denim - polished

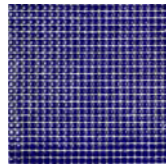

Denim - iridescent

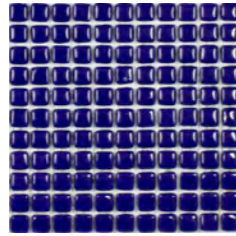

Peacock - matte

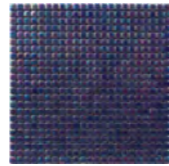

Peacock - polished

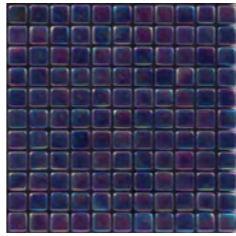

Peacock - iridescent

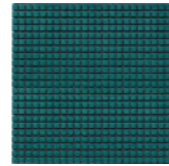

Oslo - matte

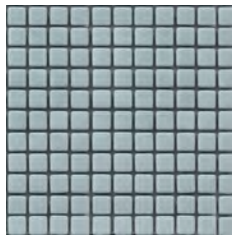

Oslo - polished

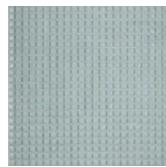

Oslo - iridescent

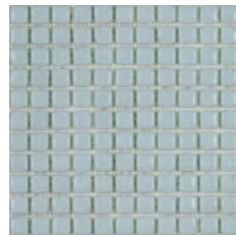

Ocean - matte

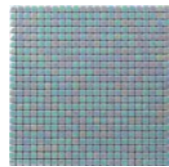

Ocean - polished

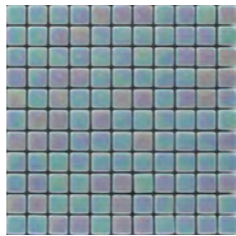

Ocean - iridescent

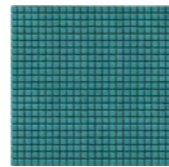

River - matte

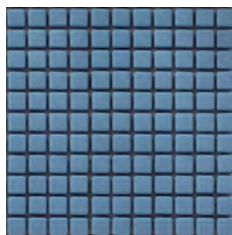

River - polished



River - iridescent

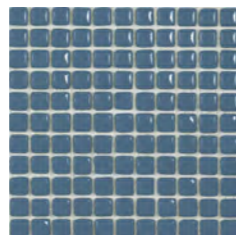

Teal - matte



Teal - polished

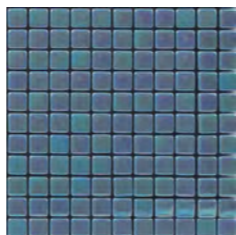

Teal - iridescent

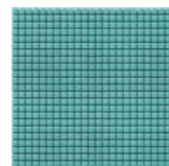

Unit: 11 12/16" x 11 12/16"
Unit Yield: 0.96 sqft
Yield per box: 9.56 sqft

Piece size: Square 1/2" x 1/2"
Sheets per box: 10
Pallet Yield: 774.26 sqft

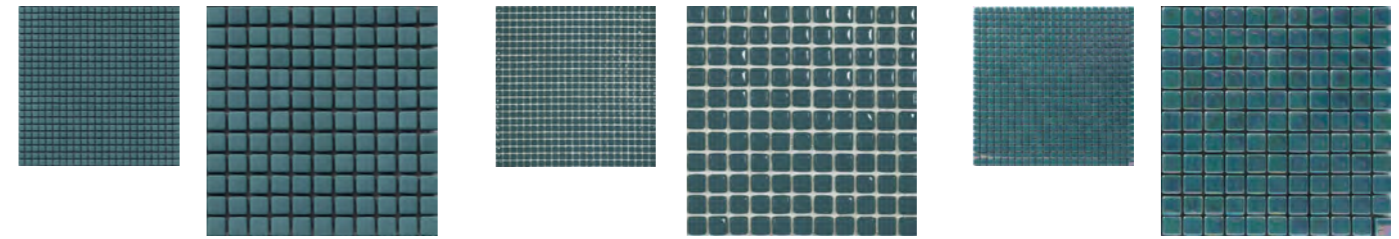

Oasis - matte Oasis - polished Oasis - iridescent

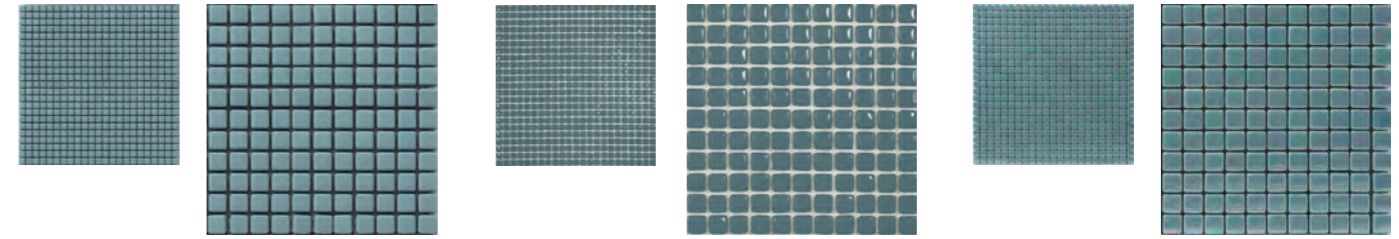

Rain - matte Rain - polished Rain - iridescent

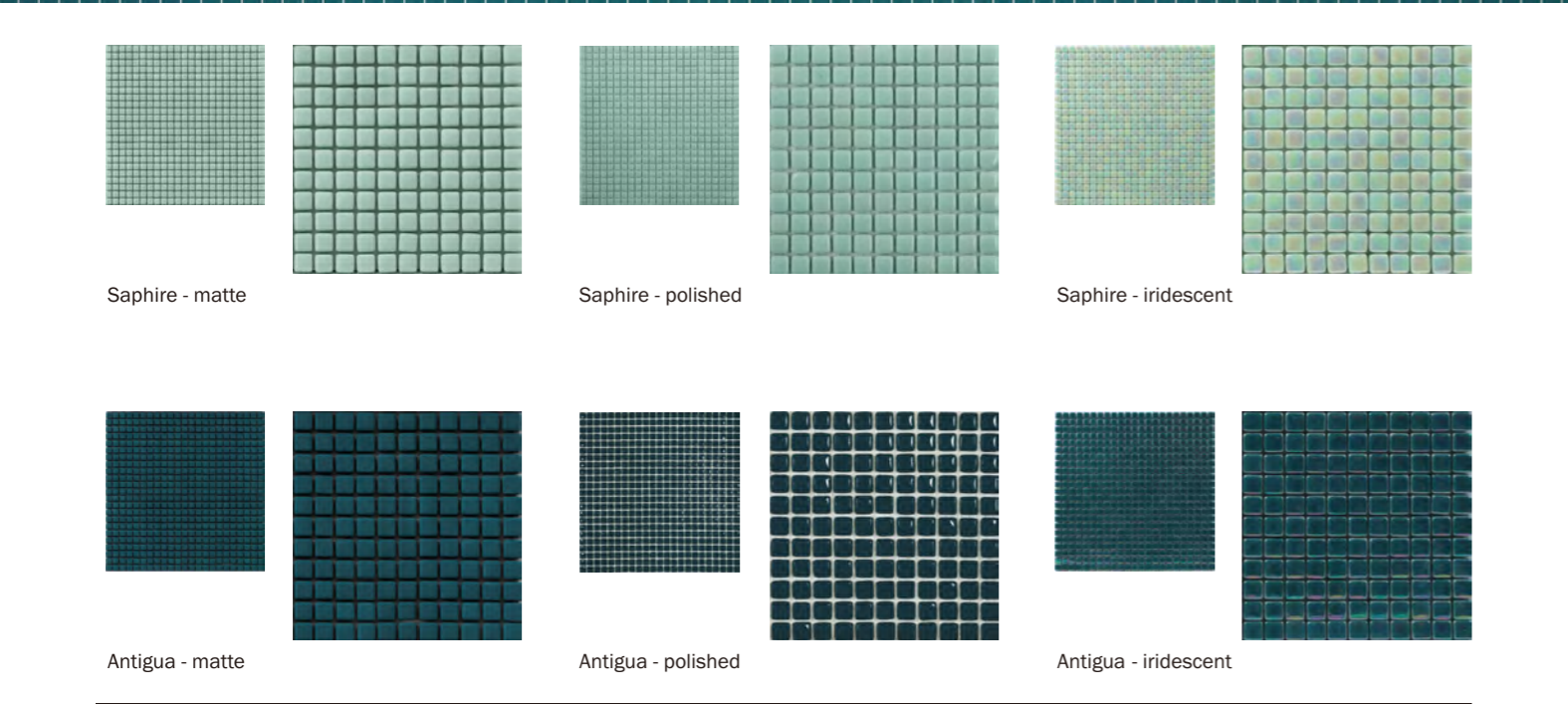

Saphire - matte Saphire - polished Saphire - iridescent

Antigua - matte Antigua - polished Antigua - iridescent



Unit: 11 12/16" x 11 12/16" Piece size: Square 1/2"x 1/2"
 Unit Yield: 0.96 sqft Sheets per box: 10
 Yield per box: 9.56 sqft Pallet Yield: 774.26 sqft

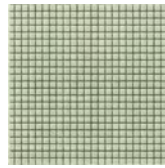

Mint - matte



Mint - polished

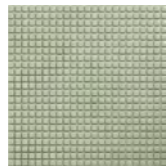

Mint - iridescent

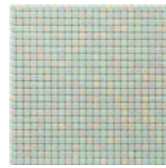

Pine - matte



Pine - polished

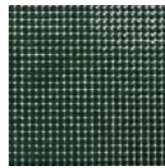

Pine - iridescent

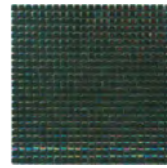
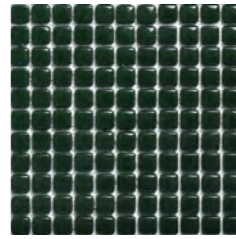

Sage - matte



Sage - polished

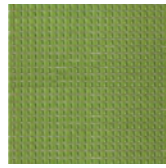

Sage - iridescent

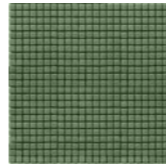
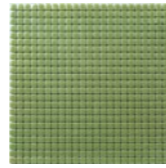

Juniper - matte



Juniper - polished

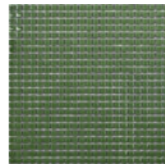

Juniper - iridescent

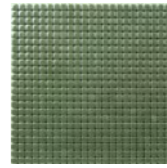
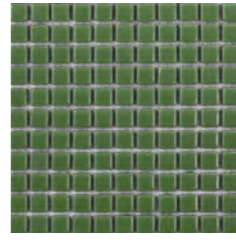

Basil - matte

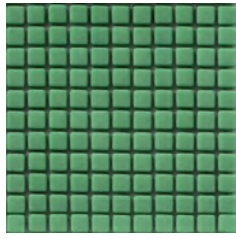

Basil - polished

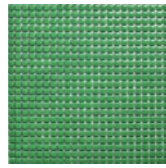

Basil - iridescent

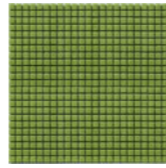
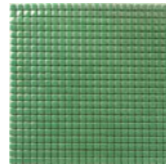

Parakeet - matte

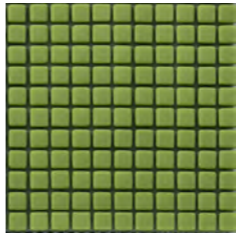

Parakeet - polished

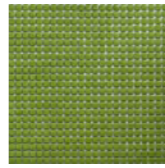

Parakeet - iridescent

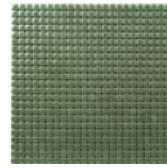
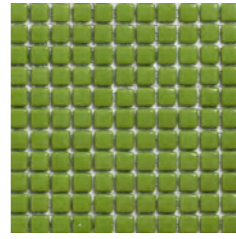

Seaweed - matte



Seaweed - polished

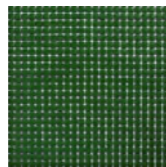

Seaweed - iridescent

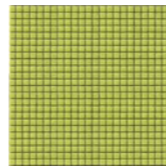
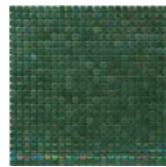

Pickle - matte

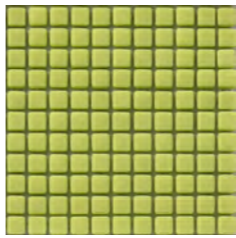

Pickle - polished

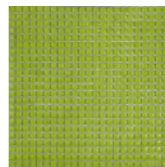

Pickle - iridescent

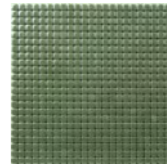
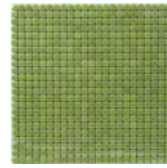
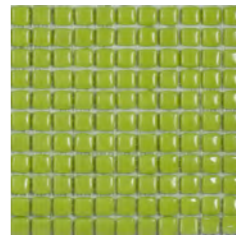



Daffodil matte

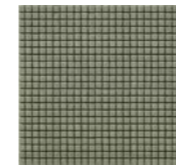

Artichoke - matte

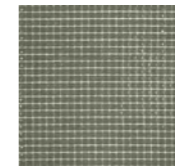
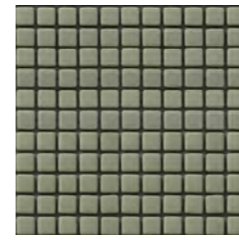

Artichoke - polished

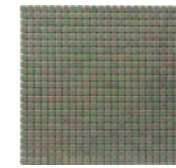
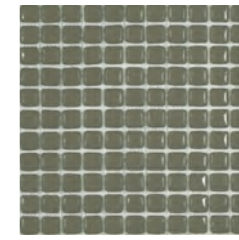

Artichoke - iridescent

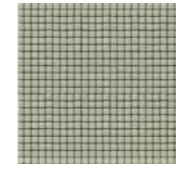
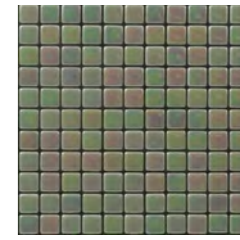

Clary - matte

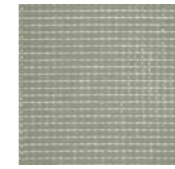
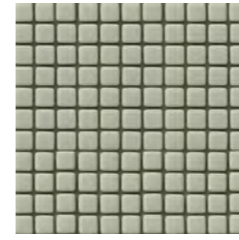

Clary - polished

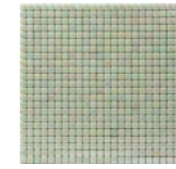
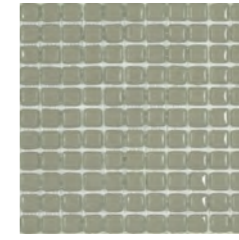

Clary - iridescent

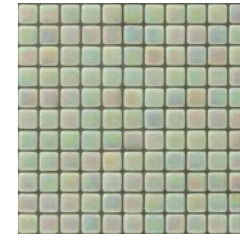

Artichoke matte

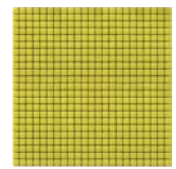

Pear - matte

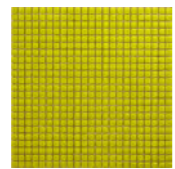
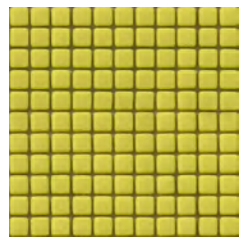

Pear - polished

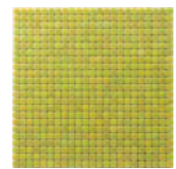
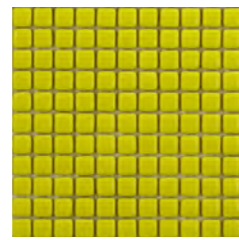

Pear - iridescent

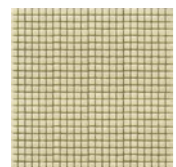
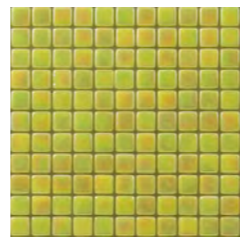

Daffodil - matte

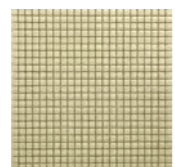

Daffodil - polished

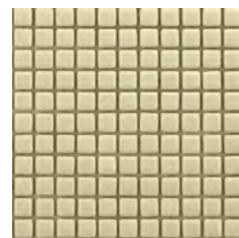

Daffodil - iridescent



Unit: 11 12/16" x 11 12/16"
Unit Yield: 0.96 sqft
Yield per box: 9.56 sqft

Piece size: Square 1/2" x 1/2"
Sheets per box: 10
Pallet Yield: 774.26 sqft

Unit: 11 12/16" x 11 12/16"
Unit Yield: 0.96 sqft
Yield per box: 9.56 sqft

Piece size: Square 1/2" x 1/2"
Sheets per box: 10
Pallet Yield: 774.26 sqft

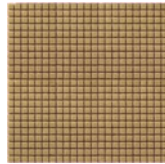

Caramel - matte

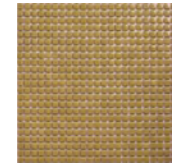
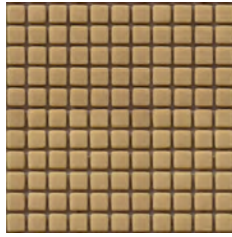

Caramel - polished

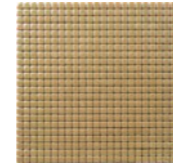
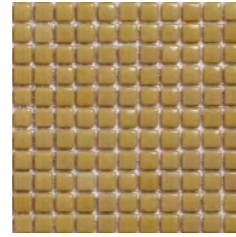

Caramel - iridescent

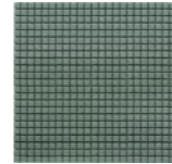
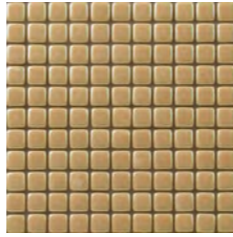

Cascade - matte

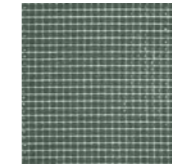
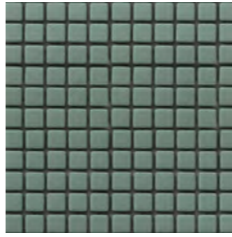

Cascade - polished

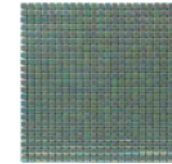
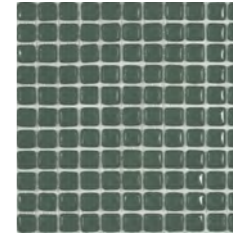

Cascade - iridescent

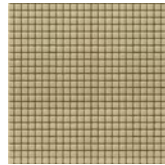
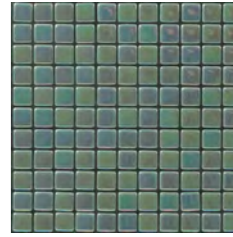

Pistachio - matte

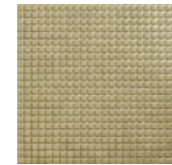
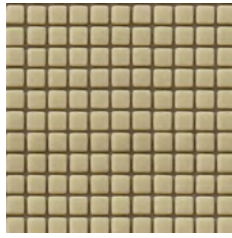

Pistachio - polished

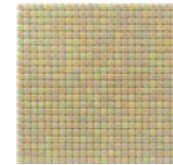
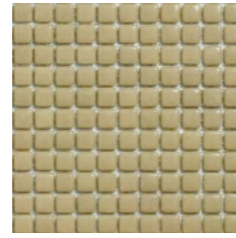

Pistachio - iridescent

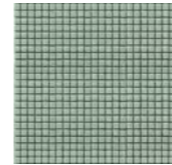
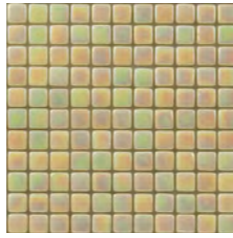

Thyme - matte

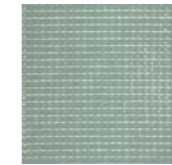
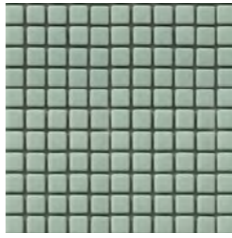

Thyme - polished

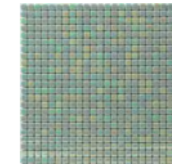
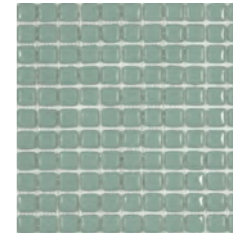

Thyme - iridescent

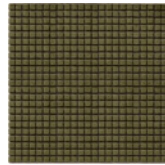
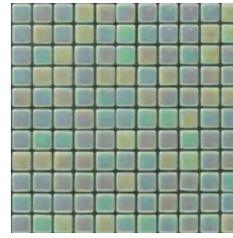

Olive - matte

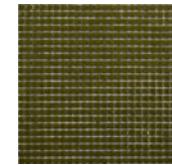
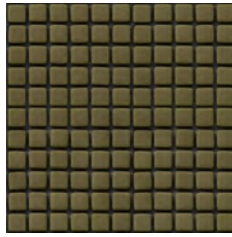

Olive - polished

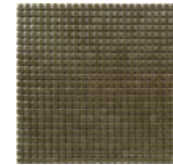
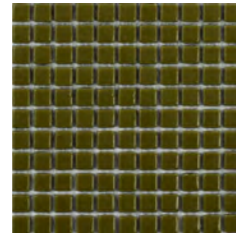

Olive - iridescent

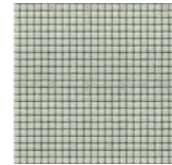
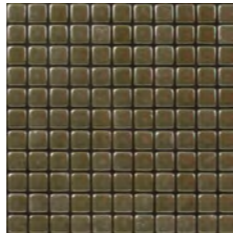

Canvas - matte

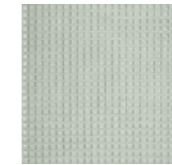
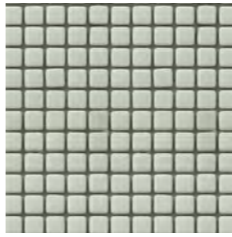

Canvas - polished

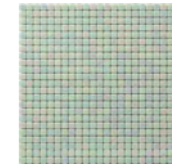
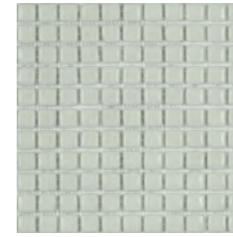

Canvas - iridescent

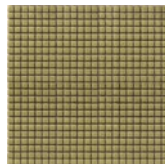
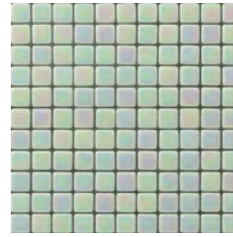

Fern - matte

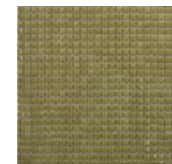
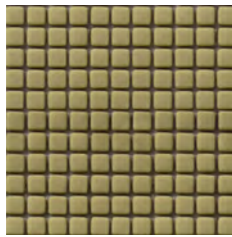

Fern - polished

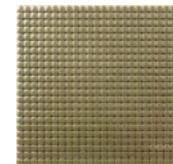
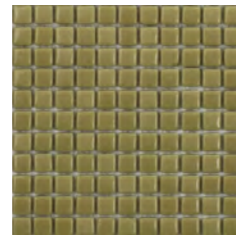

Fern - iridescent

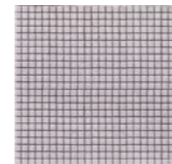
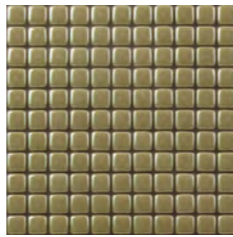

Pansy - matte

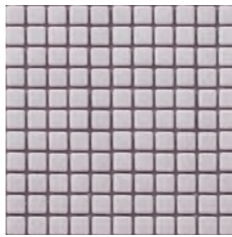

Pansy - polished

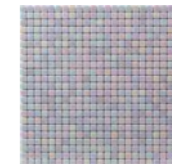
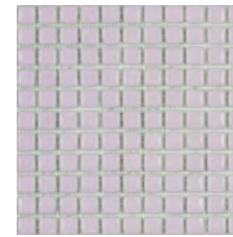

Pansy - iridescent

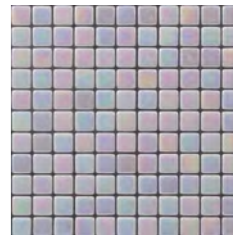



Wisteria matte

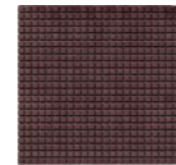

Russet - matte

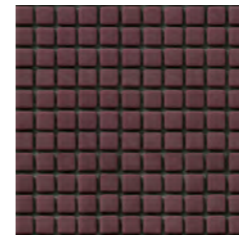

Russet - polished

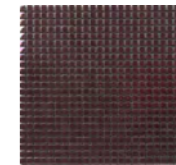
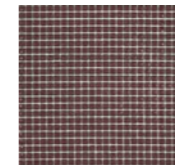

Russet - iridescent

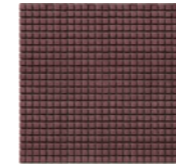
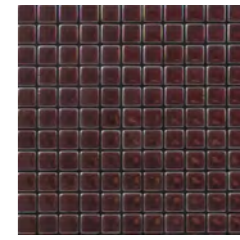

Currant - matte

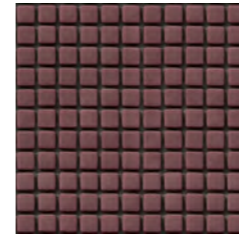

Currant - polished

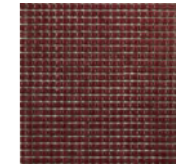
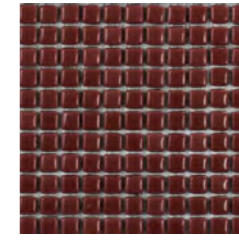
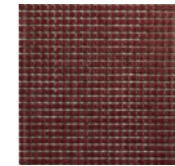

Currant - iridescent

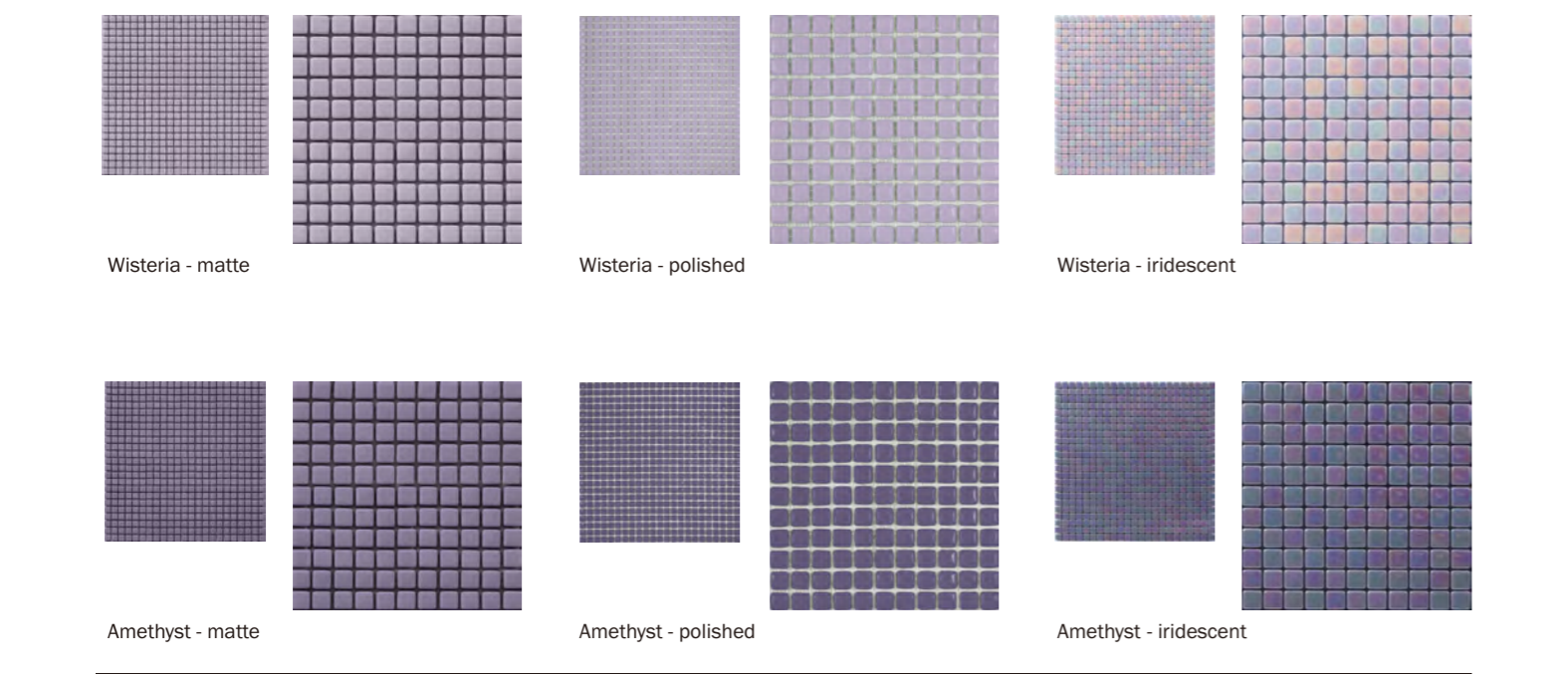
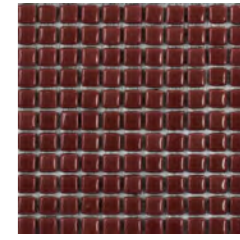

Wisteria - matte

Wisteria - polished

Wisteria - iridescent

Amethyst - matte

Amethyst - polished

Amethyst - iridescent



Currant matte

Unit: 11 12/16" x 11 12/16"
Unit Yield: 0.96 sqft
Yield per box: 9.56 sqft

Piece size: Square 1/2"x 1/2"
Sheets per box: 10
Pallet Yield: 774.26 sqft

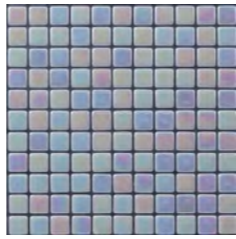
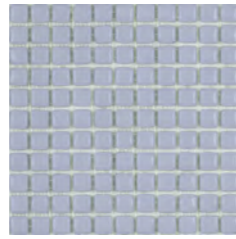
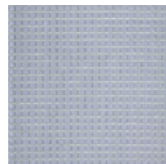
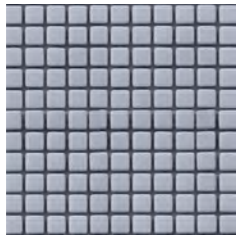
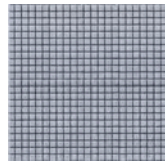

Lace - matte

Lace - polished

Lace - iridescent

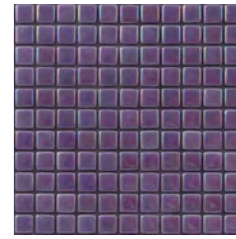
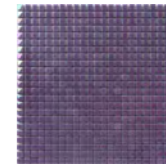
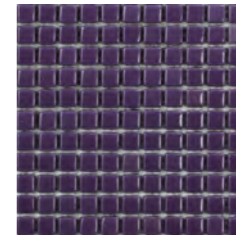
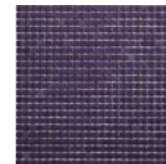
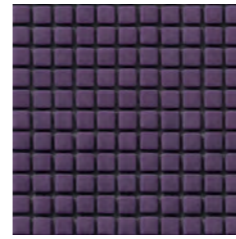
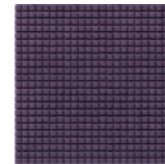

Mauve - matte

Mauve - polished

Mauve - iridescent

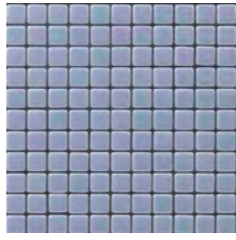
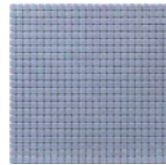
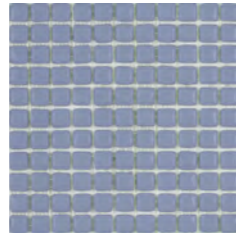
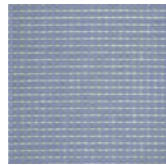
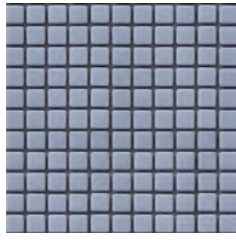
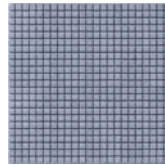

Blueberry - matte

Blueberry - polished

Blueberry - iridescent

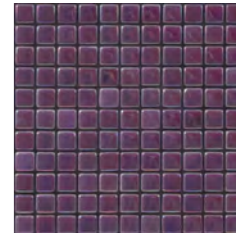
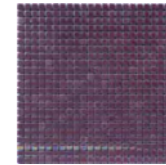
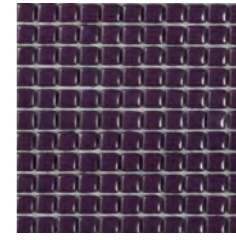
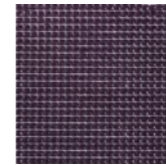
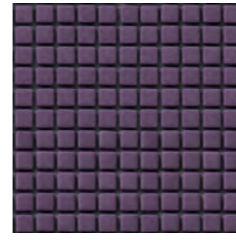
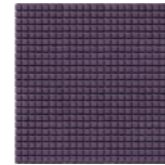

Eggplant - matte

Eggplant - polished

Eggplant - iridescent

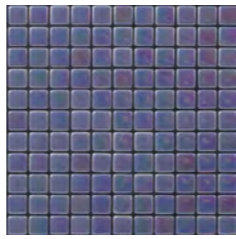
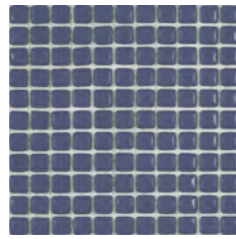
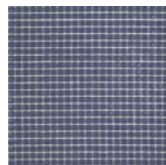
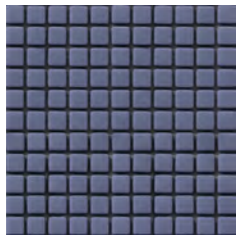
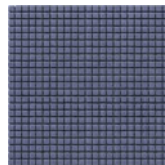

Mulberry - matte

Mulberry - polished

Mulberry - iridescent

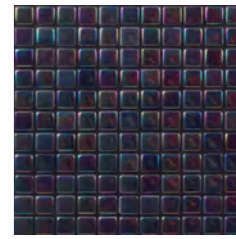
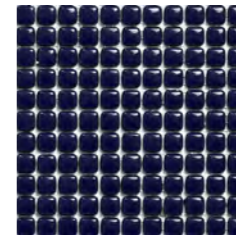
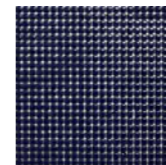
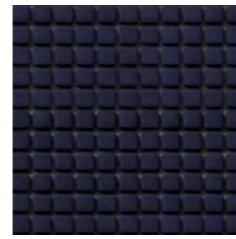

Rasin - matte

Rasin - polished

Rasin - iridescent

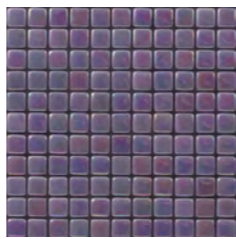
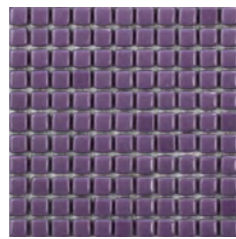
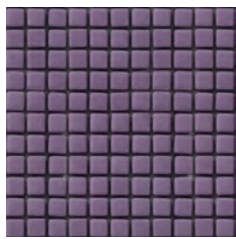
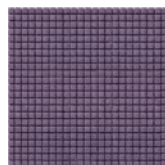

Iris - matte

Iris - polished

Iris - iridescent

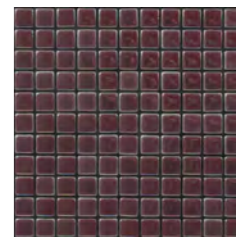
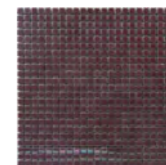
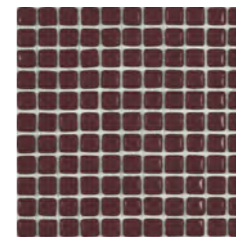
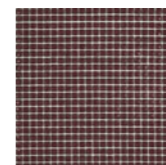
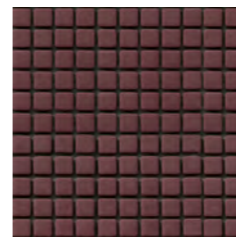
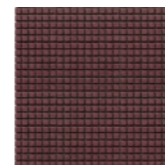

Velvet - matte

Velvet - polished

Velvet - iridescent

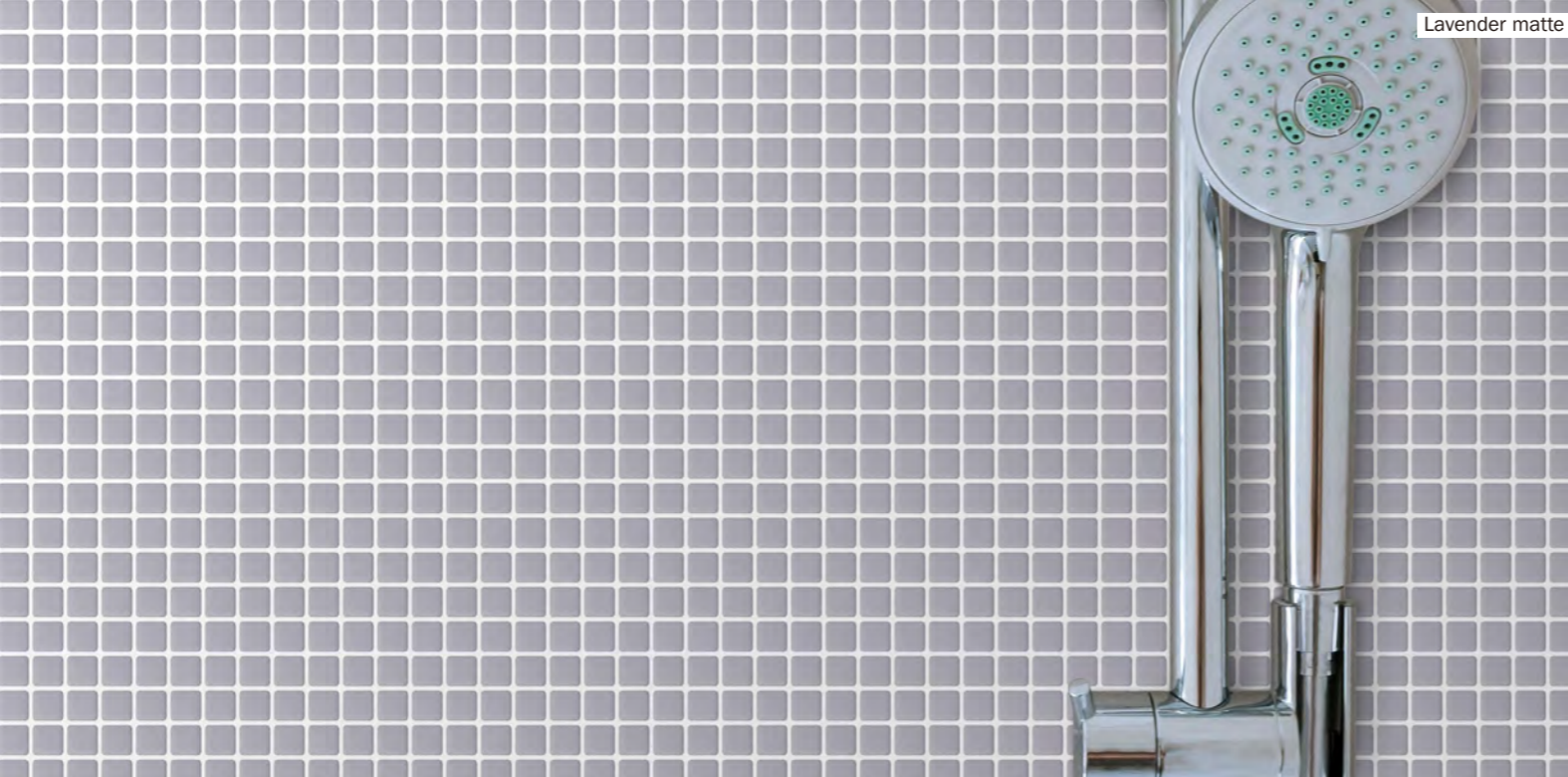

Lavender matte

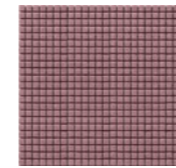

Plum - matte

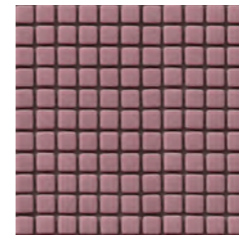

Plum - polished

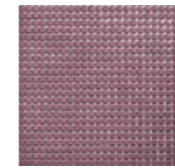

Plum - iridescent

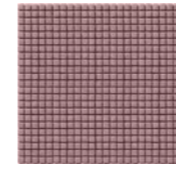
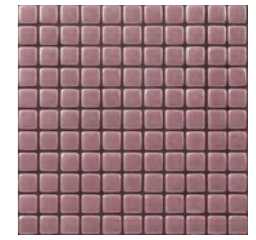
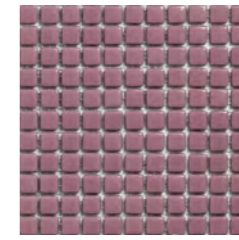

Aster - matte

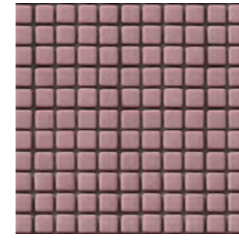

Aster - polished

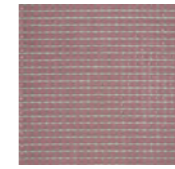

Aster - iridescent

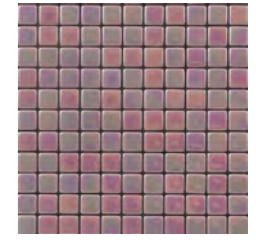
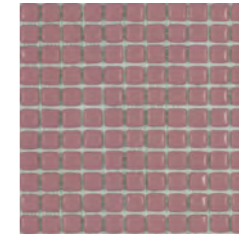

Aster matte

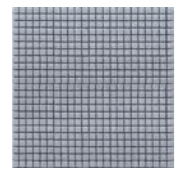

Haze - matte

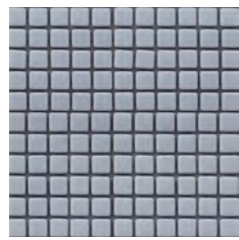

Haze - polished

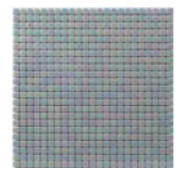

Haze - iridescent

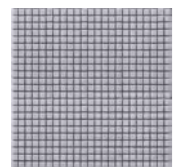
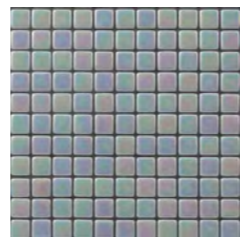

Lavender - matte



Lavender - polished

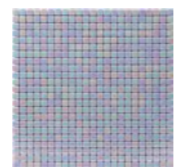
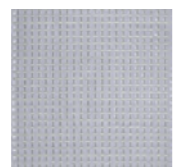

Lavender - iridescent

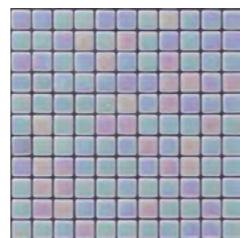

Unit: 11 12/16" x 11 12/16"
Unit Yield: 0.96 sqft
Yield per box: 9.56 sqft

Piece size: Square 1/2"x 1/2"
Sheets per box: 10
Pallet Yield: 774.26 sqft

Unit: 11 12/16" x 11 12/16"
Unit Yield: 0.96 sqft
Yield per box: 9.56 sqft

Piece size: Square 1/2"x 1/2"
Sheets per box: 10
Pallet Yield: 774.26 sqft

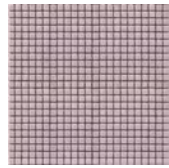

Lilac - matte



Lilac - polished

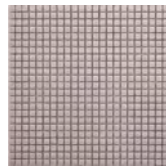

Lilac - iridescent

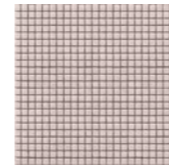
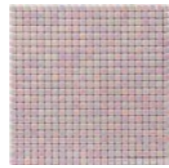

Petal - matte

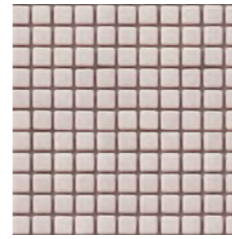

Petal - polished

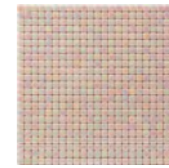
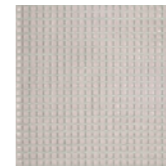

Petal - iridescent

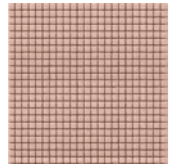
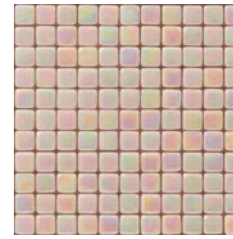

Dusty - matte

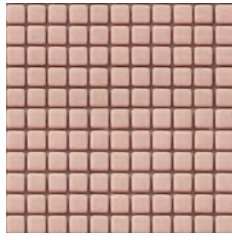

Dusty - polished

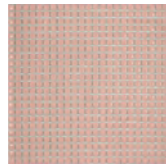

Dusty - iridescent

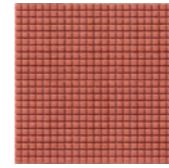
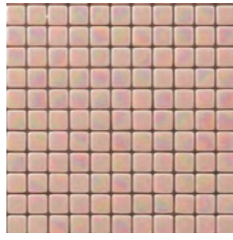
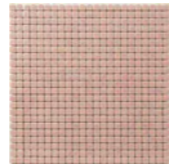

Rose - matte

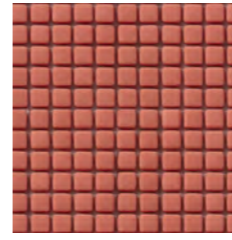

Rose - polished

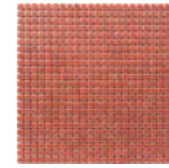
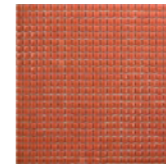

Rose - iridescent

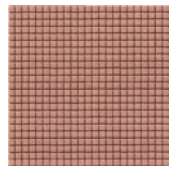
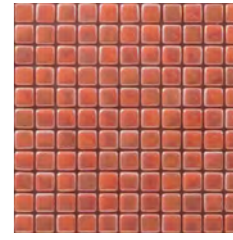

Salmon - matte

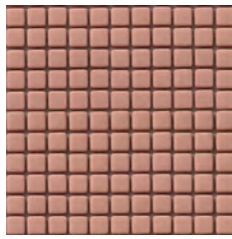

Salmon - polished

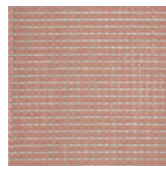

Salmon - iridescent

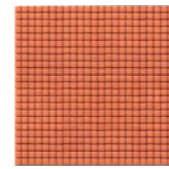
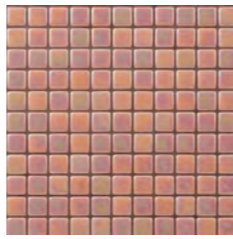
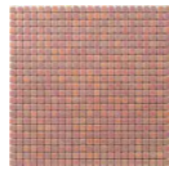

Cantaloupe - matte

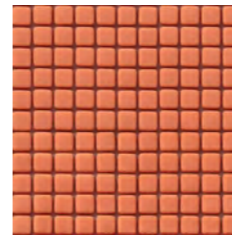

Cantaloupe - polished

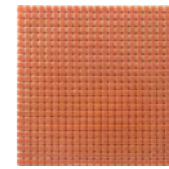
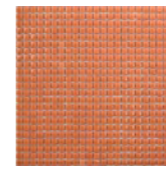

Cantaloupe - iridescent

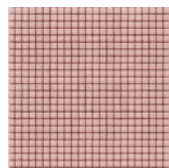
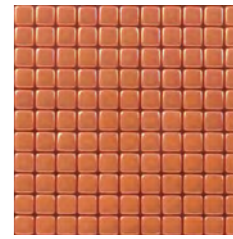

Bloom - matte

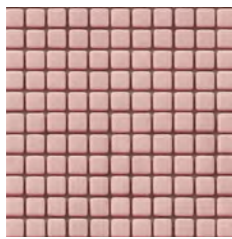

Bloom - polished

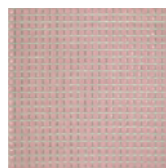

Bloom - iridescent

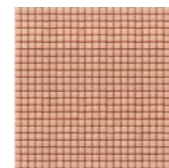
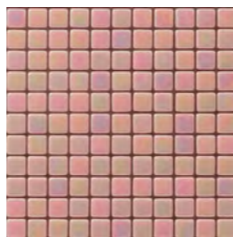

Peach - matte

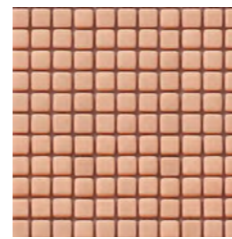

Peach - polished

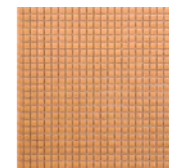
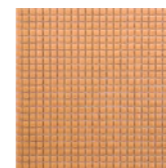

Peach - iridescent

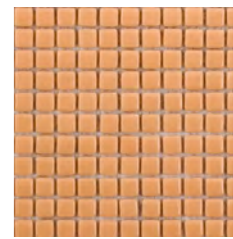



Scarlet matte

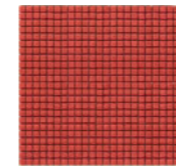

Apple - matte

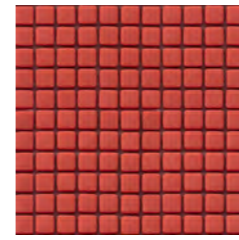

Apple - polished

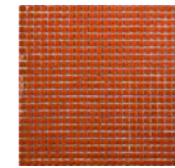

Apple - iridescent

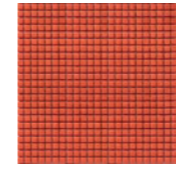
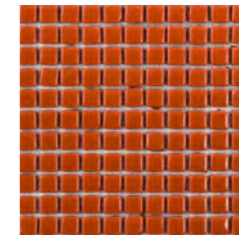

Jam - matte

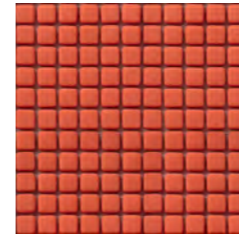

Jam - polished

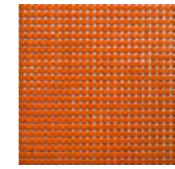

Jam - iridescent

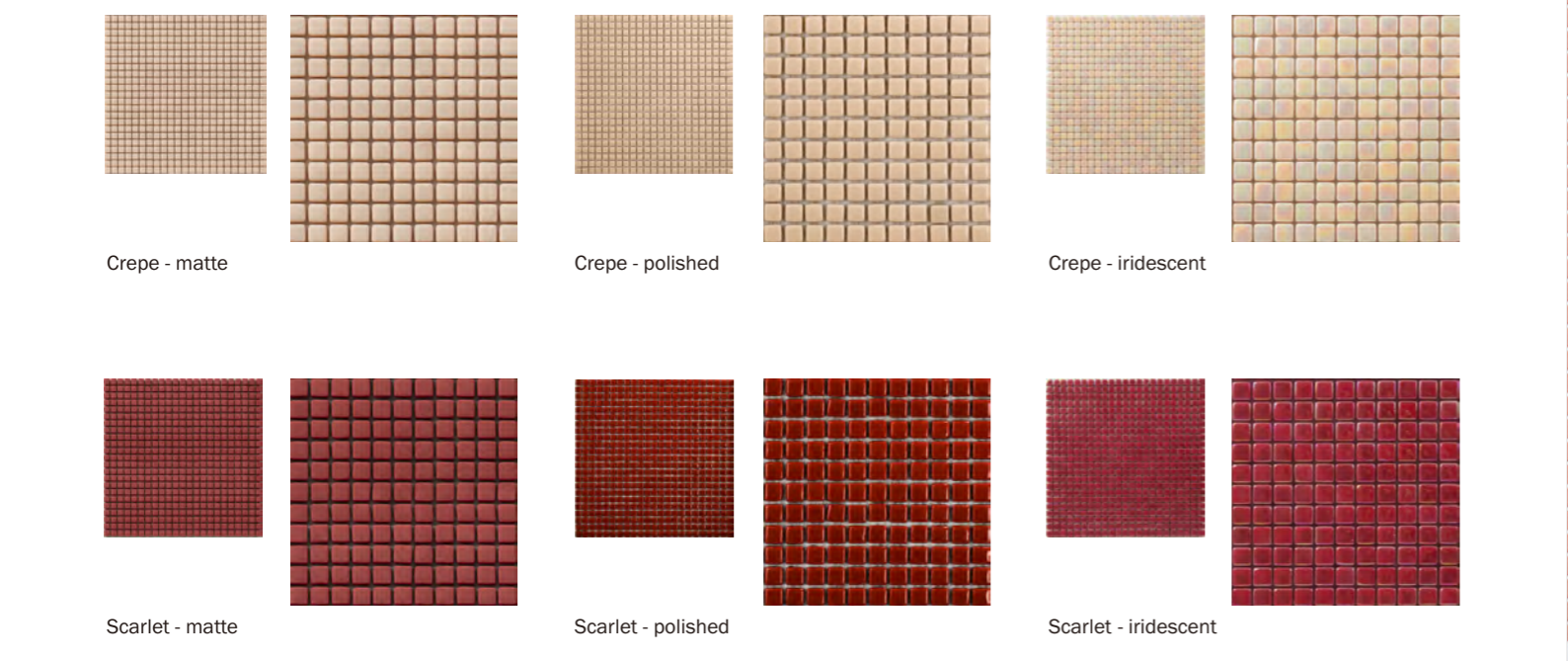
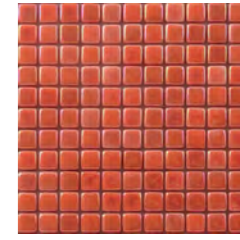
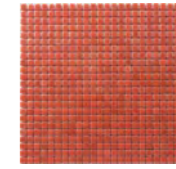
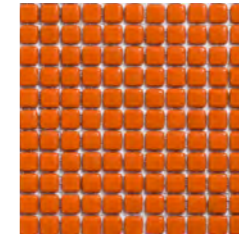

Crepe - matte

Crepe - polished

Crepe - iridescent

Scarlet - matte

Scarlet - polished

Scarlet - iridescent

Jam matte

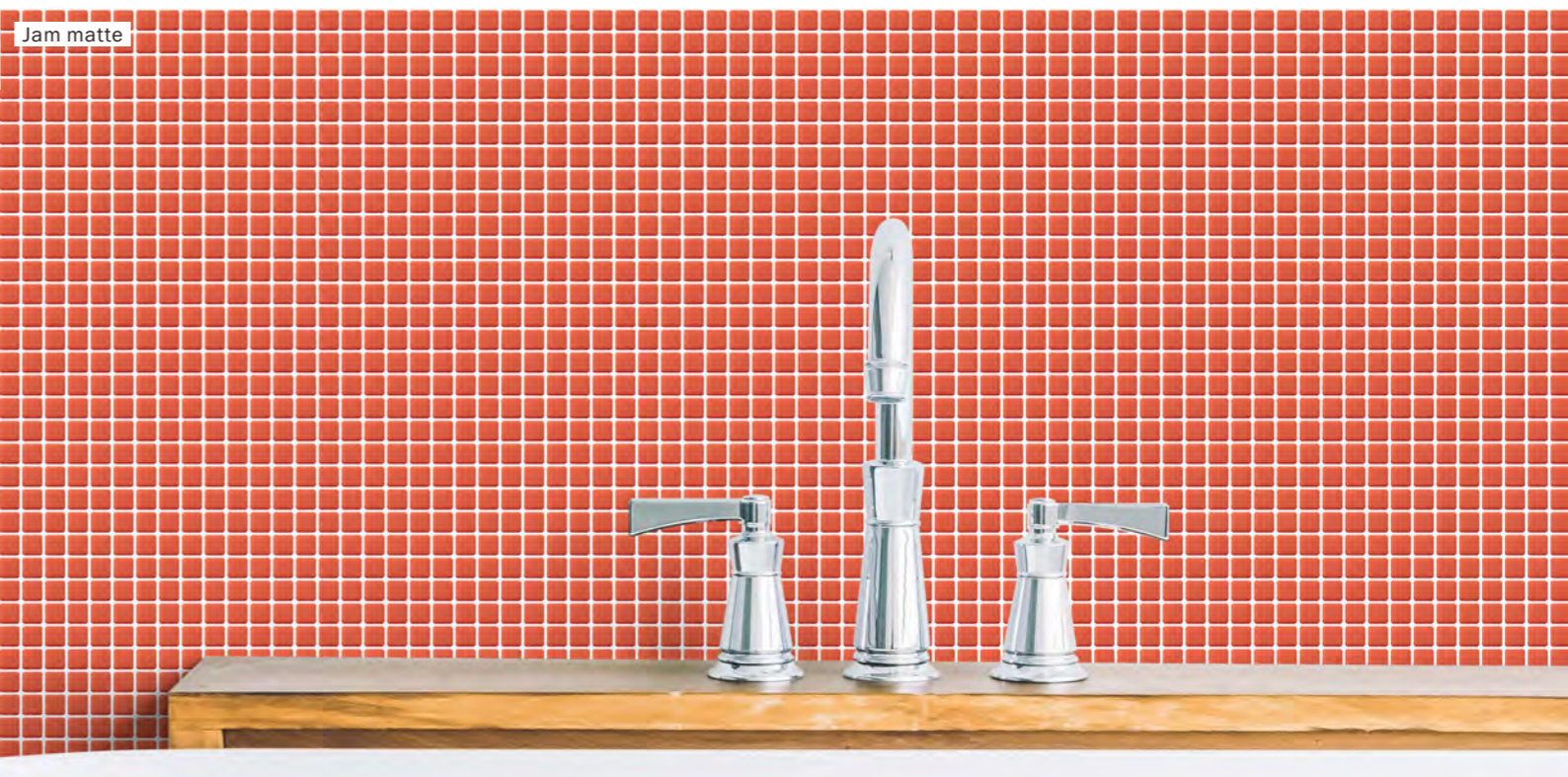

Unit: 11 12/16" x 11 12/16"
 Unit Yield: 0.96 sqft
 Yield per box: 9.56 sqft

Piece size: Square 1/2"x 1/2"
 Sheets per box: 10
 Pallet Yield: 774.26 sqft

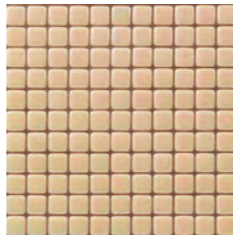
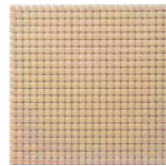
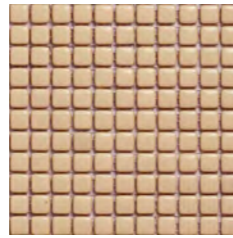
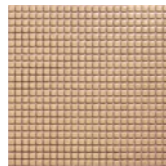
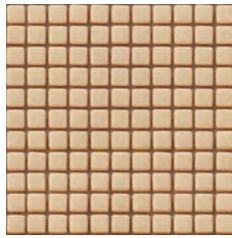
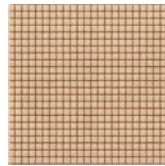

Oat - matte

Oat - polished

Oat - iridescent

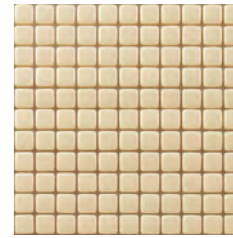
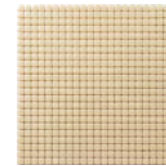
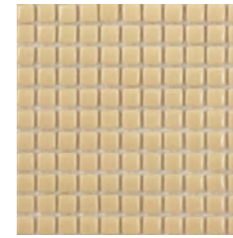
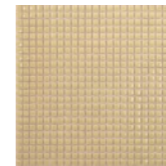
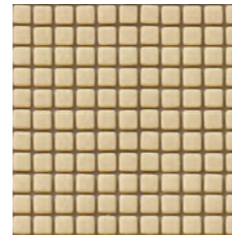

Linen - matte

Linen - polished

Linen - iridescent

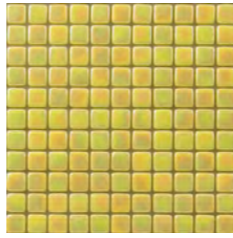
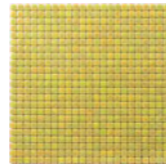
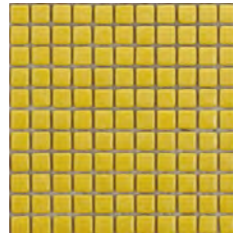
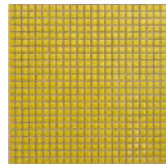
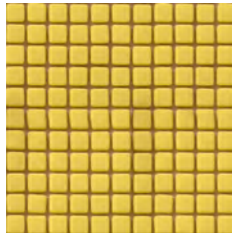
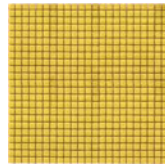

Lemon - matte

Lemon - polished

Lemon - iridescent

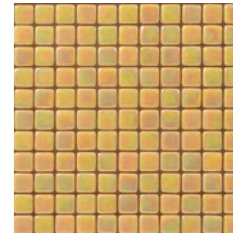
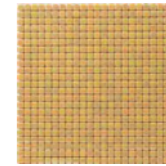
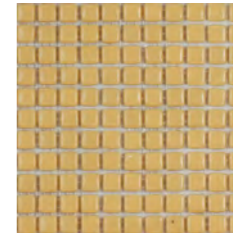
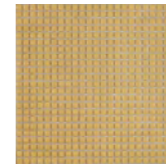
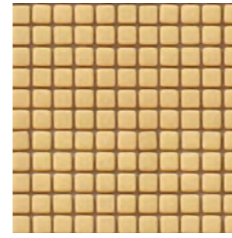
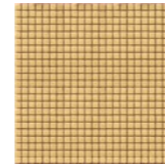

Buttermilk - matte

Buttermilk - polished

Buttermilk - iridescent

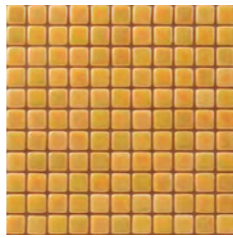
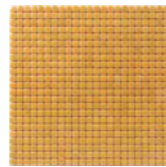
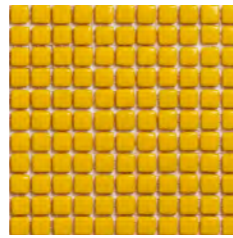
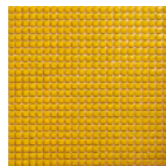
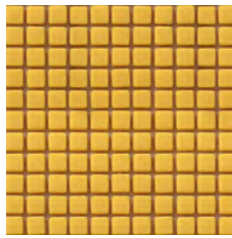
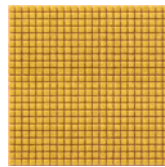

Dijon - matte

Dijon - polished

Dijon - iridescent

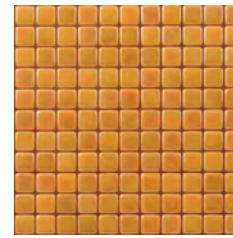
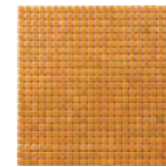
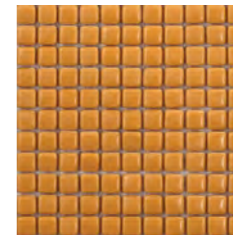
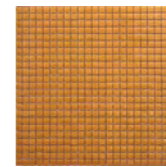
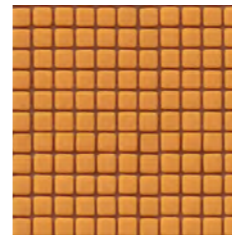
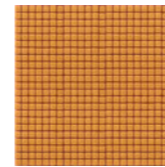

Honey - matte

Honey - polished

Honey - iridescent

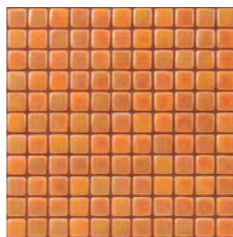
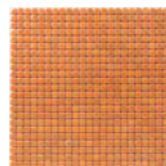
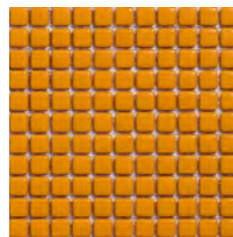
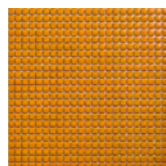
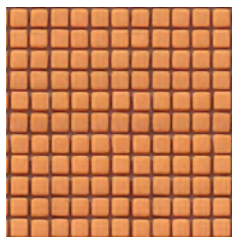
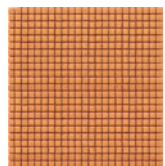

Carrot - matte

Carrot - polished

Carrot - iridescent

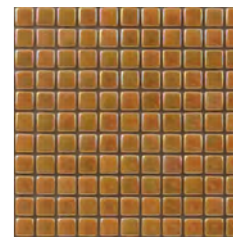
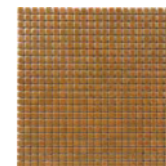
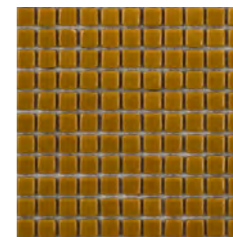
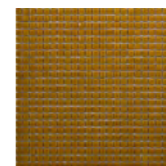
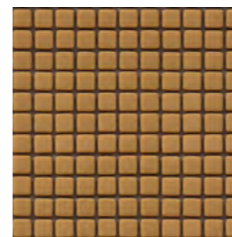
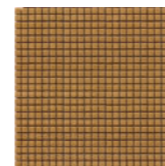

Cider - matte

Cider - polished

Cider - iridescent



Ginger matte

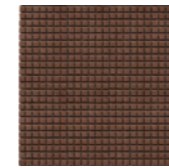

Spice - matte

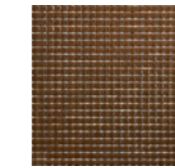
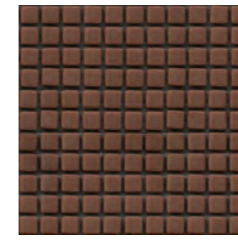

Spice - polished

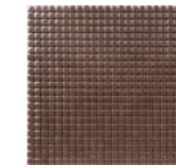
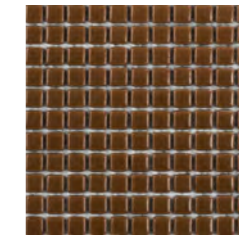

Spice - iridescent

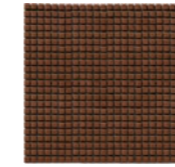
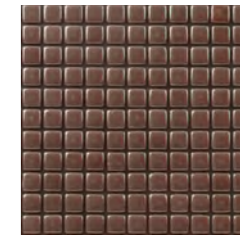

Rosewood - matte

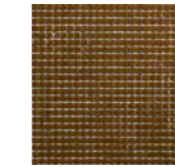
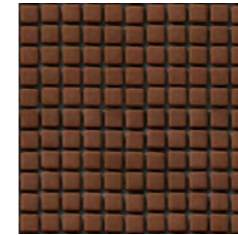

Rosewood - polished

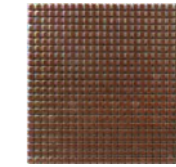
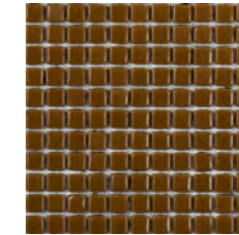

Rosewood - iridescent

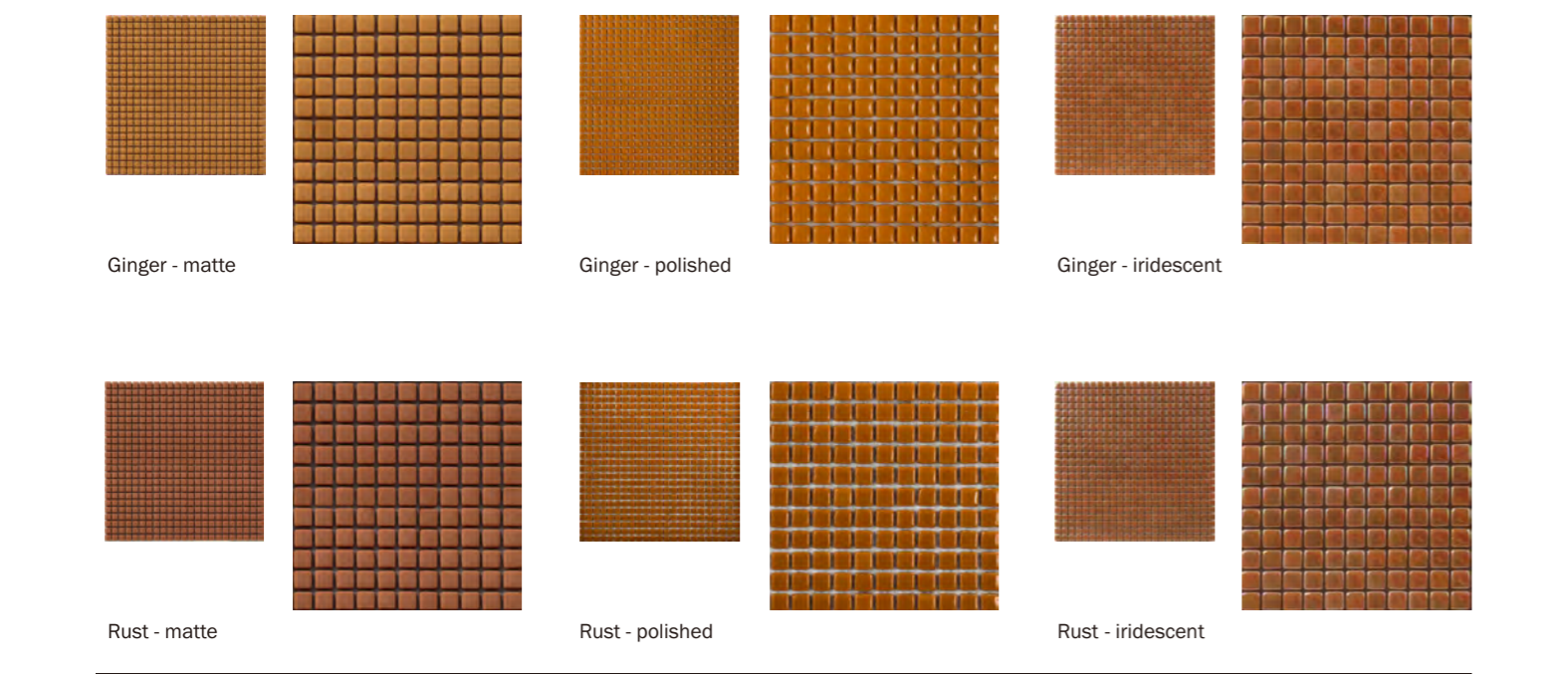
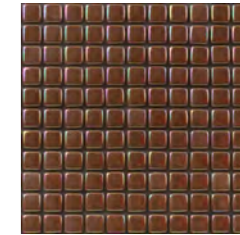

Ginger - matte

Ginger - polished

Ginger - iridescent

Rust - matte

Rust - polished

Rust - iridescent

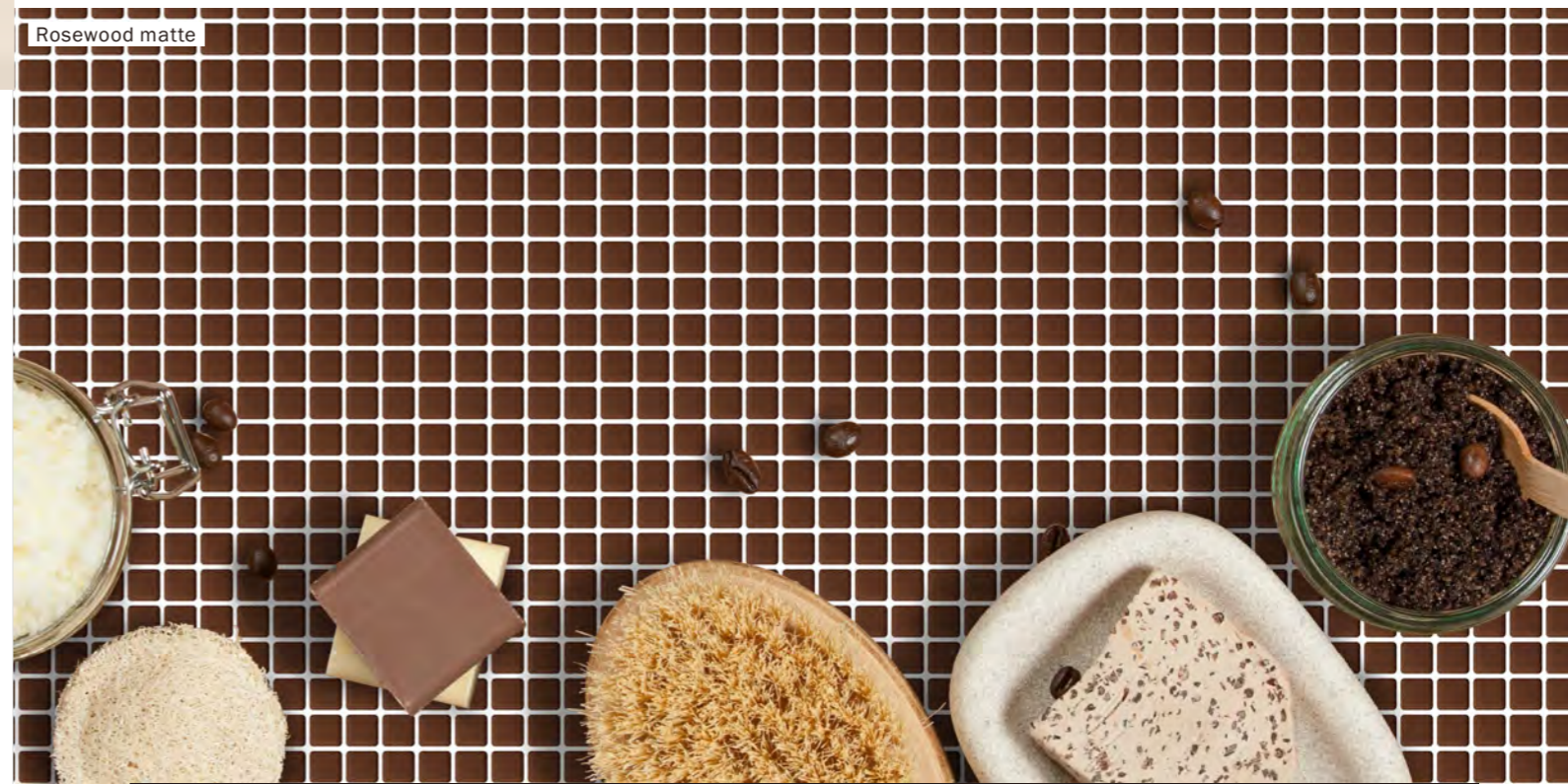

Rosewood matte

Unit: 11 12/16" x 11 12/16"
 Unit Yield: 0.96 sqft
 Yield per box: 9.56 sqft

Piece size: Square 1/2"x 1/2"
 Sheets per box: 10
 Pallet Yield: 774.26 sqft

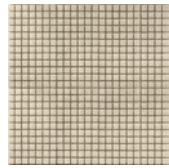

Parchment - matte



Parchment - polished

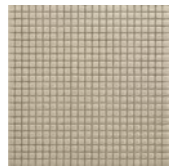

Parchment - iridescent

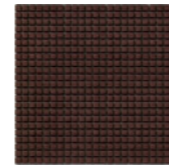
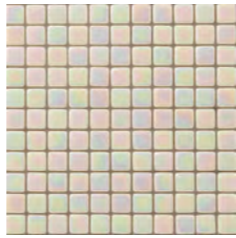
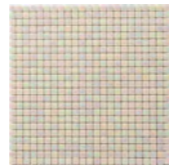

Clay - matte



Clay - polished

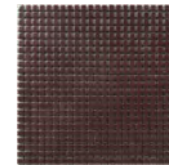
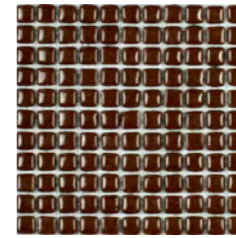
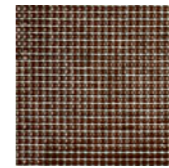

Clay - iridescent

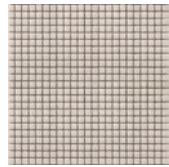

Latte - matte

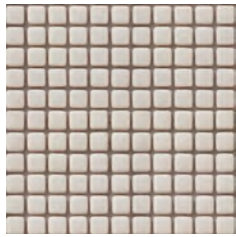

Latte - polished

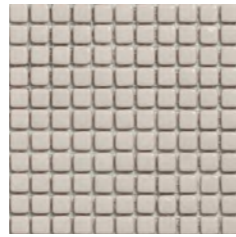
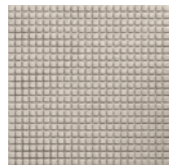

Latte - iridescent



Mahogany - matte

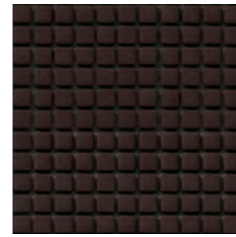

Mahogany - polished

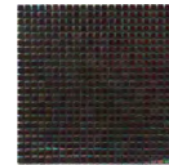
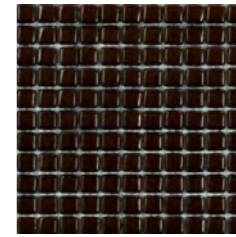
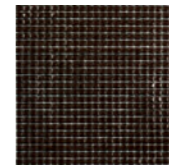

Mahogany - iridescent

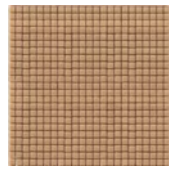
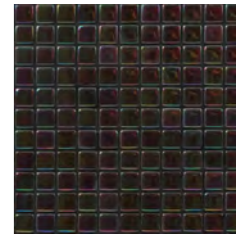

Biscotti - matte

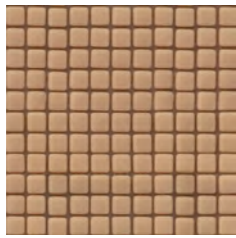

Biscotti - polished

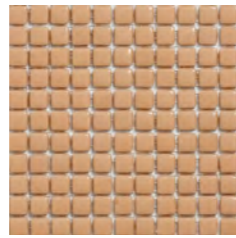
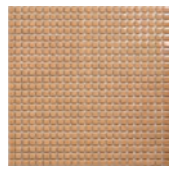

Biscotti - iridescent

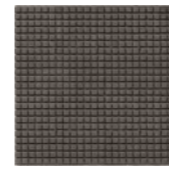
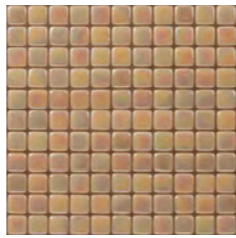

Coal - matte

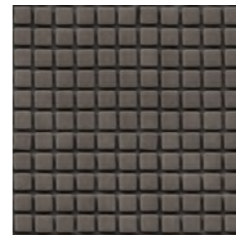

Coal - polished

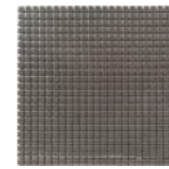
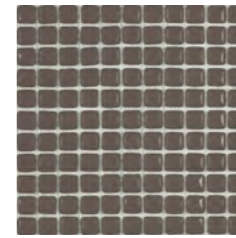
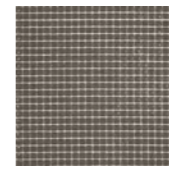

Coal - iridescent

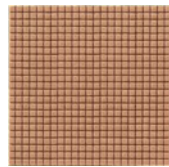
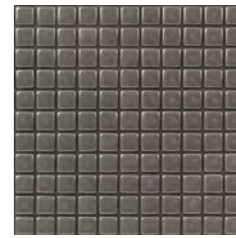

Fawn - matte

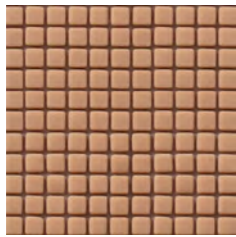

Fawn - polished

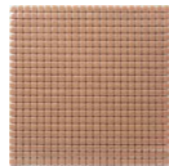
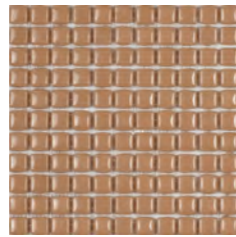
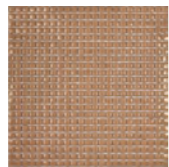

Fawn - iridescent

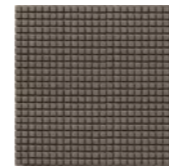
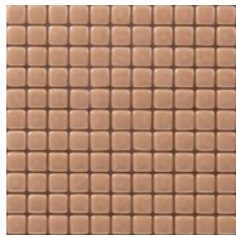

Gravel - matte

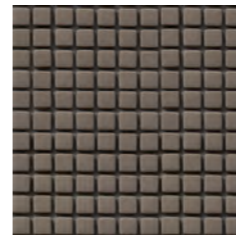

Gravel - polished

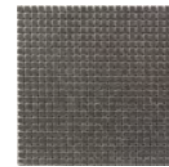
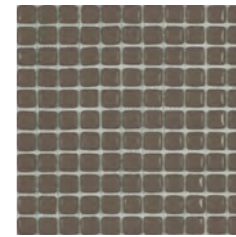
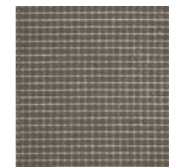

Gravel - iridescent

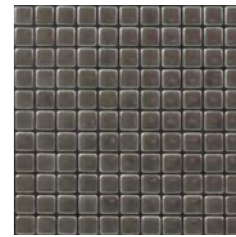



Pebble matte

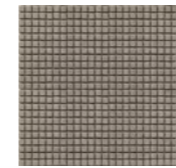

Leather - matte

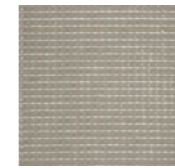
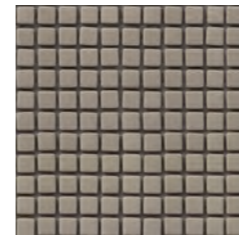

Leather - polished

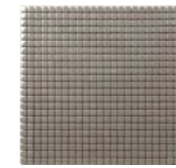

Leather - iridescent

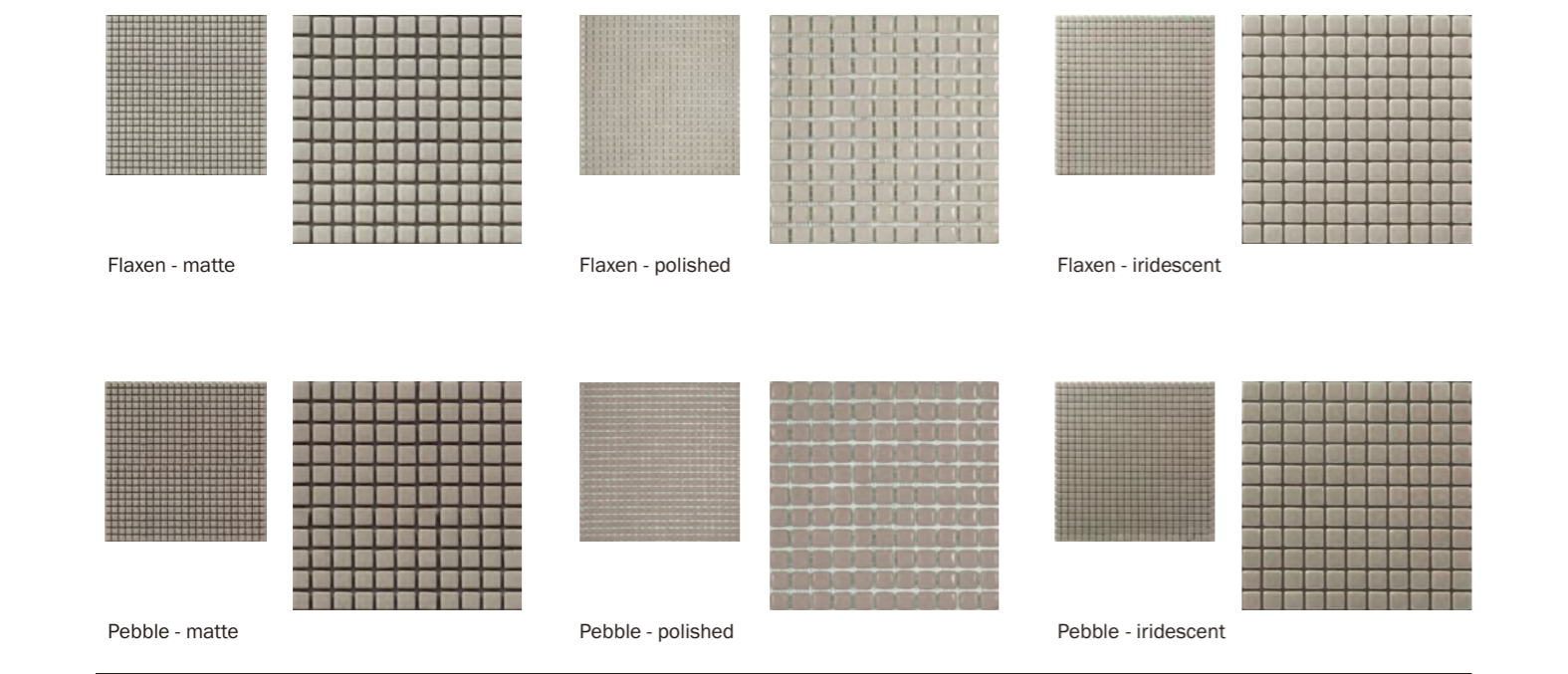
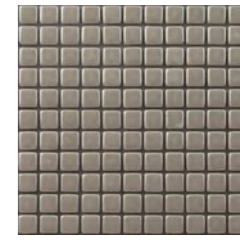

Flaxen - matte

Flaxen - polished

Flaxen - iridescent

Pebble - matte

Pebble - polished

Pebble - iridescent



Leather matte

Unit: 11 12/16" x 11 12/16"
 Unit Yield: 0.96 sqft
 Yield per box: 9.56 sqft

Piece size: Square 1/2"x 1/2"
 Sheets per box: 10
 Pallet Yield: 774.26 sqft

RECYCLED GLASS

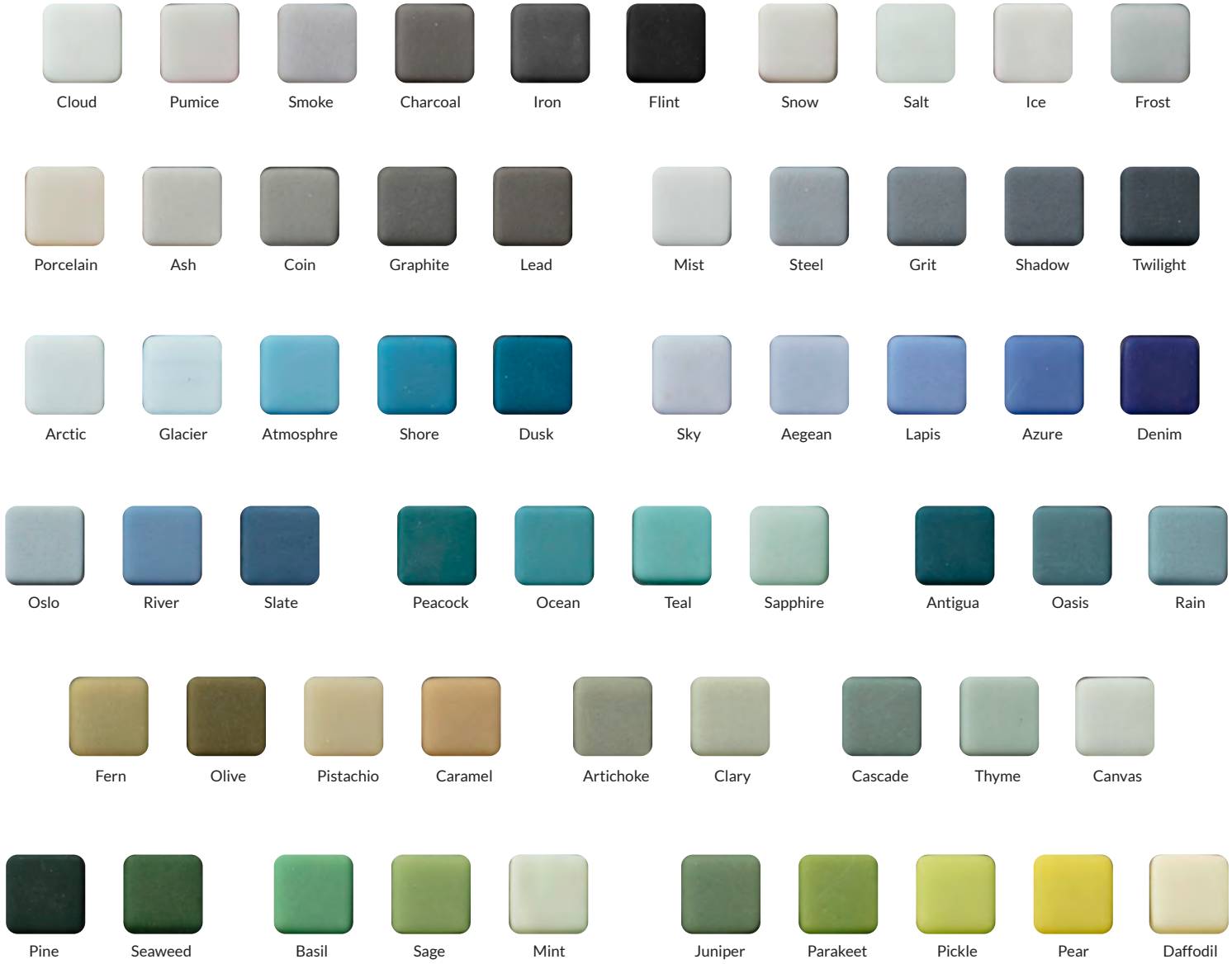
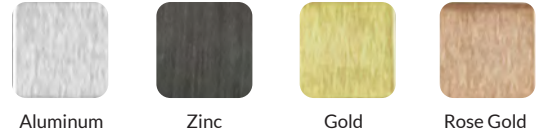

INSTALLATION

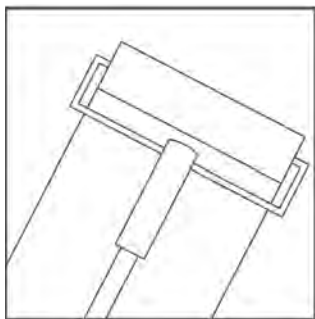

step 1

Apply a crack insulation membrane over substrate per the membrane manufacturer's instruction. Using the flat side of a trowel to initiate the bond coat. Firmly apply the setting material to the substrate.

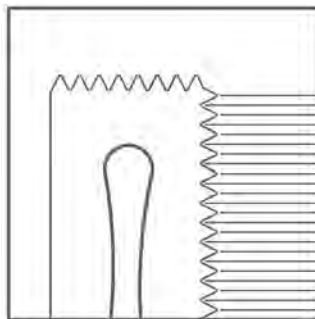

step 2

With additional setting materials, using a 1/4" x 1/4" V-Notch trowel, comb horizontal, full notches in one direction to establish the proper depth of the setting bed.

**only necessary if there is translucent glass*
Using the flat side of the trowel, flatten the notches to achieve a smooth, consistent setting bed approximately 1/8" thick.

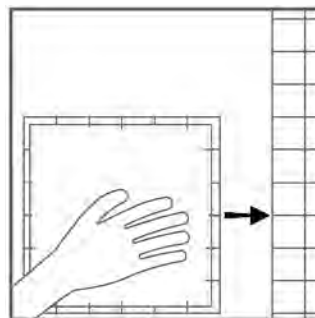

step 3

Apply sheets into the setting bed (tile tape side towards you), using light, even pressure to establish contact and eliminate any voids. Apply each subsequent sheet so that grout joints line up and a consistent field is maintained.

******Prior to setting each sheet, check the setting bed for skinning (slight drying of the thin set surface). If skinning occurs, remove thin set and repeat steps 2 and 3. Pay particular attention to the joints between sheets to eliminate any sheet pattern.

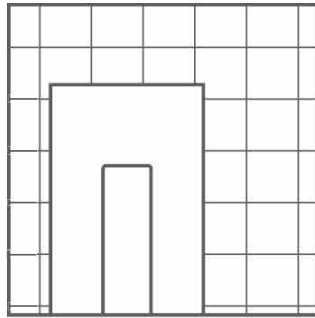

step 4

To achieve a uniform surface:
glass and small piece mosaics= tap lightly using a rubber grout
Large pieced mosaics= use a wooden beating block and a hammer.

**To unify transitions tap from one sheet to the next.*

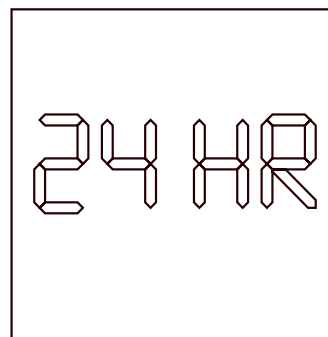

step 5

Cure a minimum of 24 hours prior to cleaning and grouting.

**Check setting materials manufactures specifications for recommended curing time.*

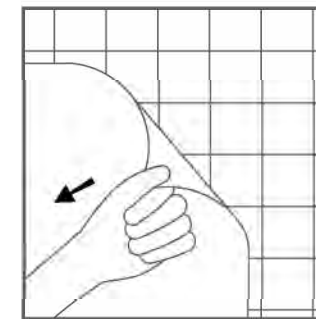

step 6

After approved setting time you may peel the face tape, starting at the corner.

Clean any tape residue with a damp sponge.

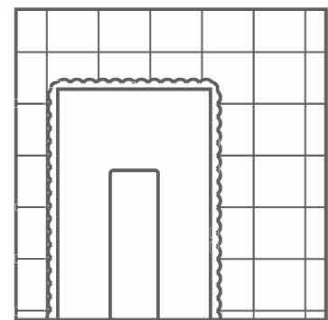

step 7

Use grout mixed per manufacturers instructions. When grout joints are 1/32" or less, use a non sanded grout. Apply grout with a rubber float, forcing grout into joints until full.

If the mosaic contains both stone and glass (or metal), expect the grout to dry and set faster around the stone. Due to the impervious nature of glass and metal, grout will take longer to set than with more porous materials such as stone.

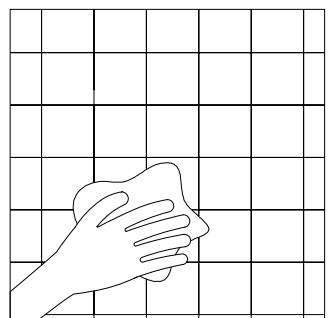

step 8

Allow grout joints to take initial set (turn dull). For initial cleaning use clean, dry cheesecloth. This method wicks additional moisture from the grout and avoids washing out the grout joints.

step 9

Allow grout joints to set up a second time (turn dull) and smooth.

step 10

For final polishing of excess grout haze use a clean, soft cloth.

SETTING SYSTEMS

All materials should be used according to manufacturer's instructions. If the mosaic includes glass tiles, please note that due to the translucent nature of glass, the color of the bonding material will impact the ultimate look of the tile. We recommend the use of specific white bonding mortars; some mixed with specific latex admix. See the following list for required thin-set and follow manufacturer's recommended cure times for all setting materials. Pools, spas and all submerged applications require a minimum 21-day cure time after grouting and before submersion or exposure to heavy water use.

Although we require the use of highest performing setting materials for installing our products, occasionally, due to the transparent and/or light translucent nature of some of our products, visible effects, also known as "ghosting", may occur behind glass tiles.

When mixing setting and grouting materials:

1. Measure liquid and powder per manufacturer's recommendations.
2. Machine mixing will provide more consistent results.
3. Do not exceed 300 rpm or manufacturer's recommendations.
4. Setting and grouting materials need to slake (set) 10-15 minutes after mixing and be remixed before use.

Acceptable Setting Systems (White)

- Custom Building Products: MegaFlex Crack prevention Mortar
- Custom Building Products: MegaLite Crack Prevention Mortar
- Flextile: 52 Versatile Floor Mortar
- Hydroment™ ReFlex Ultra-Premium Latex-Modified Thin Set Mortar
- Kerakoll: H40 Tenax Single Component Thin-Set
- Laticrete: 254 Platinum Multipurpose Thin Set Mortar
- Mapei: Adhesilex P10 mixed with Keraply mortar additive
- TEC (H.B. Fuller): Super Flex Premium Performance Universal Latex-Modified Thin-Set Mortar
- FOR METAL (Geometro): Litokol LitoElastic Epoxy

Unacceptable Setting Systems

- Organic adhesive (mastic) – due to yellowing and low bond strength
- Epoxy – due to low flexibility, as well as degeneration in UV sunlight

Movement Joints

Movement joints are essential for the success of most tile installations. Follow recommendations on Movement Joints EJ171-07 in the "2008 TCA Handbook for Ceramic Tile Installation." Movement joint requirements will vary depending on substrate, climate and size of installation. An architect or design professional should be consulted when specifying the exact number and location of each movement joint. Saw-tooth joints are not recommended. Certain application may require a different type of sealant.

Acceptable Flexale Joint Fillers

- Hydroment: Chem-Calk 900 One-Part Urethane Sealant
- Kerakoll: Sigibuild PU Poly-Urethane Sealant
- Laticrete: Latasil 100% Silicone
- Silaflex: 1A or 2C Polyurethane-based Sealant

SETTING SYSTEMS

Grout

Install grout mix according to manufacturer's instructions. Grout should be full and uniformly finished. Due to the impervious quality of glass, the grout will take longer to begin setting-up. For initial cleaning of grout from the tile face, use clean, dry cheesecloth. This wicks additional moisture from the grout and avoids washing out the joints. Use on a clean, damp sponge for the final cleaning and smoothing of the joints. For final polishing of excess haze use a clean, soft cloth.

Acceptable Grouts

- Custom Building Products: Prism SureColor Grout (can go in pools)
- Custom Building Products: Fusion Grout
- Custom Building Products: Polyblend Sanded Tile Grout
- Flextile: 600 Polymer Sanded Floor Grout
- Hydroment: Sanded Ceramic Tile Grout
- Kerakoll: Fugabella 2-12
- Laticrete: 1500 Series Tile Grout or Equivalent
- Mapei: Ker200 Series and Ker700 Series Ultra/Color
- Tec: AccuColor Premium Sanded Tile Grout
- Litokol Starlike (for LeMer)
- Litokol Starlike grout or Customs Prism (for Gunmetal - Geometro)

An Acrylic grout admix can improve freeze-thaw resistance. Check manufacturer's recommendations.

Unacceptable Grout

- Epoxy Grout – due to low flexibility, as well as degeneration in UV sunlight
- Non-sanded grout – due to shrinkage
- Consult grout manufacturers before considering blue, green or red grout in submerged applications.

Anti-Fracture/Waterproofing Membranes

- Aquafin 1K and 2K/M: Cementitious waterproofing system
- Custom Building products: RedGard Waterproofing and Crack Prevention Membrane
- Hydroment: Gold Anti-fracture and waterproofing membrane
- Laticrete: 9235 waterproof & anitfracture membrane
- Tec: T1-324 Triple-Flex waterproofing/crack isolation membrane
- Xypex: Concentrate

NOTE: We do not recommend membranes directly behind the setting material when installing translucent or transparent glass tile.

RECYCLED TEST RESULTS

Test Results of ROHS Directive

Tested Elements	Results(ppm)
CADMIUM (cd)	ND
LEAD (cd)	ND

ppm= parts per million
ND= Not Detected

Radioactivity of Building Materials

RADIOACTIVITY OF BUILDING MATERIALS WERE EVALUATED IN ACCORDANCE WITH GB 6566-2010, TYPE A DECORATION MATERIALS.

Tested Elements	Results
RADIUM-226 Radioactivity Rate Activity, Bq/kg	4.906
THORIUM-232 Radioactivity Rate Activity, Bq/kg	2.999
POTASSIUM-40 Radioactivity Rate Activity, Bq/kg	48.61

TYPE A DECORATION MATERIALS

Requirements	Results
IRRADIATION < 1.0	< 0.1
EXTERNAL IRRADIATION < 1.3	< 0.1

RADIOACTIVITY OF BUILDING MATERIALS CONFORM TO REQUIREMENTS SPECIFIED IN GB 6566-2010, TYPE A DECORATION MATERIALS.

Recycled Content of Material

THE FACTORY DECLARES THAT THE CONTENTS OF ENAMEL GLASS MOSAIC ARE SILICA (SIO2) AND ZIRCONIUM SILICATE; AND ALL MATERIALS ARE RECYCLED FROM COLLET. NO OTHER NEW RAW MATERIALS ARE ADDED DURING THE MANUFACTURING PROCESS. THE RECYCLED CONTENT OF MATERIALS IS 98%.

Water Absorption

Group No.	Test Method	Test Results (%)	
1	ISO 10545-3:1995	1.00	Average: 0.67
2		0.43	
3		0.49	
4		0.57	
5		1.09	
6		0.66	
7		0.51	
8		0.61	
9		0.63	
10		0.72	

Specimen dimensions: 20mm X 20mm x 7mm, 9pcs in each group

Resistance to Stain

Group No.	Test Method	Green Staining	Iodine 13g/L	Olive Oil
1	ISO 10545-14:1995	5	5	5
2		5	5	5
3		5	5	5
4		5	5	5
5		5	5	5

Specimen dimensions: 20mm X 20mm X 7mm, 15pcs

Thermal Stability

Test Items	Test Method	Test Results
Thermal Stability	With reference to GB/T 7697-1996	No cracking or breakage on the surface of all test specimens
Thermal Shock Resistance	ISO 10545-9:2013	Fully resistance
Frost Resistance	ISO 10545-12: 1995/Cor I: 1997	Fully resistance

Specimen dimensions: 20mm x 20mm x 7mm, 50pcs

Coefficient of Friction

Test method: GB/T 4100-2006 Annex M Determining the Coefficient of Friction of Ceramic Tile Specimens: 170mmx170mm, 3pcs, all test samples were cut from the products with the size of 320mmx320mm

Test Items	Test Results
Coefficient of Friction for Dry Surface	0.77
Coefficient of Friction for Wet Surface	0.50

Resistance to Surface Abrasion

Test method: Refer to ISO 10545-7:1996 Ceramic tiles-part 7: Determination of resistance to surface abrasion for glazed tiles

Specimens: mosaic

Test Results: After 1500 revolutions, visual failure occurred.

Chemical Resistance

Test method: GB/T 4100-2006 Annex M Determining the Coefficient of Friction of Ceramic Tile Specimens: 170mmx170mm, 3pcs, all test samples were cut from the products with the size of 320mmx320mm

Aqueous test solutions		Test Results	
Household chemicals	Ammonium chloride solution, 100g/l	Visual examination	Class: GA
Swimming pool salts	Sodium hypochlorite solution, 20mg/l	Visual examination	Class: GA
Low concentrations acids & alkalis	Hydrochloric acid solution, 3%(V/V)	Visual examination	Class: GLA
	Citric acid solution, 100g/l	Visual examination	Class: GLA
	Potassium hydroxide solution, 30g/l	Visual examination	Class: GLA

ISO 13006:2012 Ceramic tiles -Definitions, classification, characteristics and ,marking

Properties	Test Method	Requirements	Results	Verdicts
Physical property				
Water absorption percent mass fraction	ISO 10545-3: 1995/Cor. 1: 1997	Eb>10% Individual minimum 9%	11.7% 11.2%~ 12.2%	P
Thermal shock resistance	ISO 10545-9:2013	Test method available	Fully resistance	-
Frost resistance	ISO 10545-12: 1995/Cor 1: 1997	required	Fully resistance	P
Chemical Property				
Resistance to staining				
a) Green staining agent in light oil	ISO 10545-14:2015	Minimum Class 3	Class 5	P
b) Red staining agent in light oil	ISO 10545-14:2015	Minimum Class 3	Class 5	P
c) Olive oil	ISO 10545-14:2015	Minimum Class 3	Class 5	P
Resistance to chemicals & swimming pool salts				
a) Household chemicals: Ammonium chloride, 100g/L	ISO 10545-13:2016	Minimum GB	A	P
b) Swimming pool salts: Sodium hypochlorite solution, 20mg/L	ISO 10545-13:2016	Minimum GB	A	P
Resistance to low concentrations of acids and alkalis				
a) Hydrochloric acid solution, 3% (v/v)	ISO 10545-13:2016	Manufacturer to state classification	LB	-
b) Citric acid solution, 100g/L	ISO 10545-13:2016	Manufacturer to state classification	LA	-
c) Potassium hydroxide, 30g/L	ISO 10545-13:2016	Manufacturer to state classification	LA	-
Resistance to high concentrations of acids and alkalis				
a) Hydrochloric acid solution, 18% (v/v)	ISO 10545-13:2016	Test Method available	HB	-
b) Lactic acid, 5% (v/v)	ISO 10545-13:2016	Test Method available	HA	-
c) Potassium hydroxide, 100g/L	ISO 10545-13:2016	Test Method available	HA	-
Lead & Cadmium release				
a) Lead release, in mg/dm ²	ISO 10545-15:1995	Test Method available	<0.01	-
b) Cadmium release, in ng/dm ²	ISO 10545-15:1995	Test Method available	<0.002	-

1. P(ass): Test item does meet the requirement.
2. F(ail) : Test item, does not meet the requirement.
3. -: Verdict was not carried out.
4. N/A: Test case does not apply to the test item

METALLIC TEST RESULTS

Name of Sample	Stainless Steel Mosaics	Nominal size (N)	31cmx26.5cm
Nature of Surface	Glazed (GL)	Work size (Sw)	310mmx265mmx8mm
Group	BIII	Description of Samples	The samples are sound, intact and fit for test.
Mark of Samples	SS130D	Quantity of samples	30 Pieces
Test Standard	ISO 13006:2012 Cera1nic tiles -Definitions, classification, characteristics and marking Annex L Dry-pressed ceramic tiles Eb > 10 % Group BIII		
Conclusion of Test	The results conform to the requirement of Annex L of standard ISO 13006:2012 with respect to the test items.		

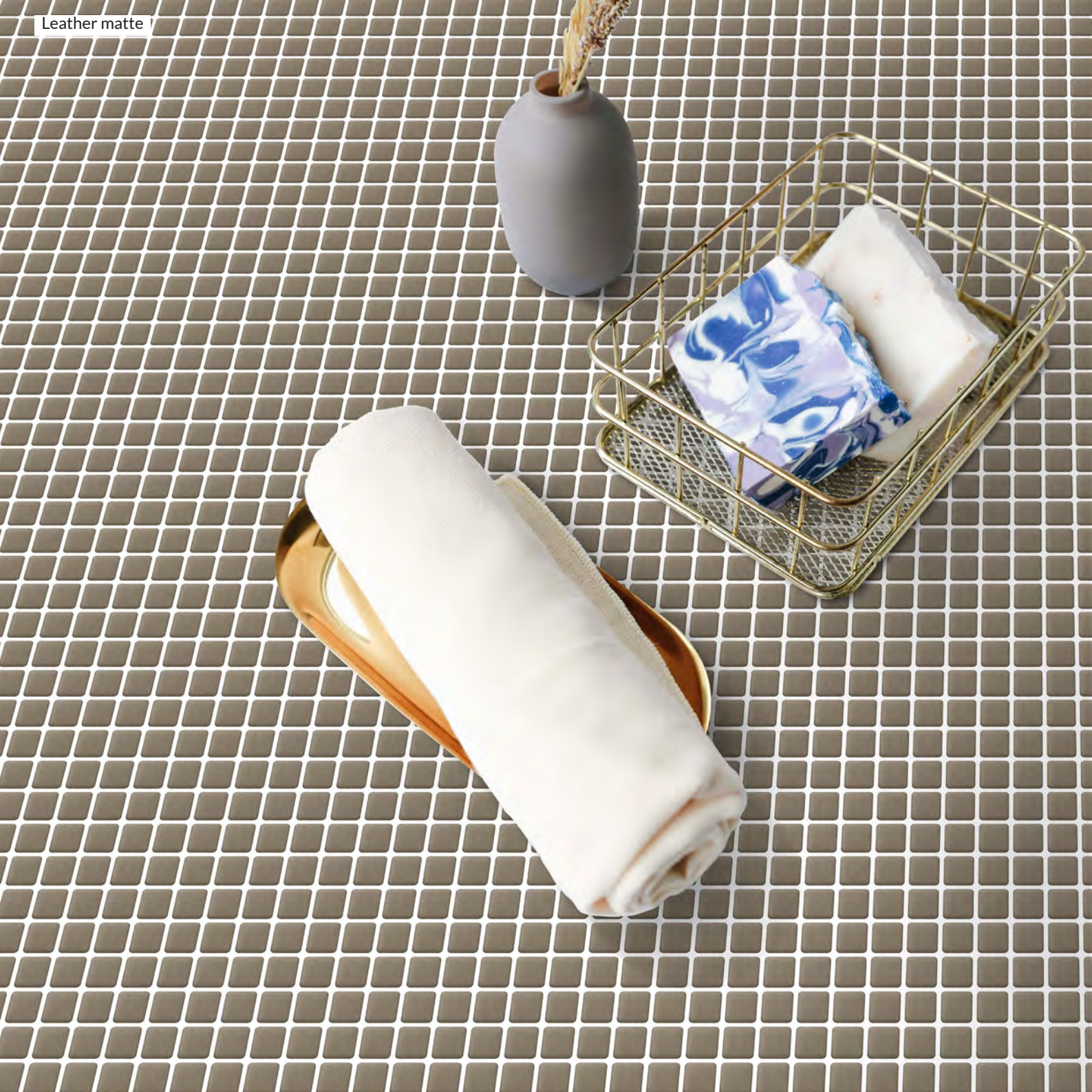

Applications:



Interior Wall

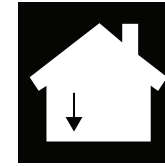

Interior Floor

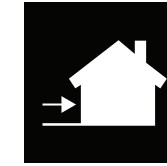

Exterior Wall

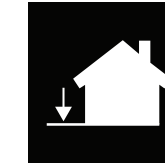

Exterior Floor

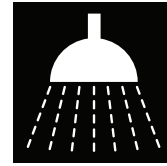

Shower

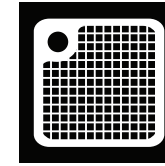

Wet/Shower Floor



Spa/Steam Room



Table/Surface Top



Pool/ Submersion

Specifications:



Lineal Thermal Expansion Tested

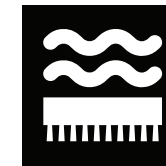

Abrasion Resistant



Frost Resistant



Chemical Resistant

resistant to staining agents

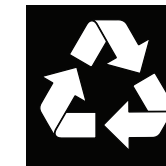

Made from Recycled Material & Can be Recycled

mantel face & hearth, not approved for interior firebox



INDEX

A	
<u>Aegean</u>	10
<u>Amethyst</u>	21
<u>Antigua</u>	13
<u>Apple</u>	30
<u>Applications & Spec</u>	54
<u>Arctic</u>	8
<u>Artichoke</u>	18
<u>Ash</u>	7
<u>Aster</u>	26
<u>Atmosphere</u>	8
<u>Azure</u>	11
B	
<u>Basil</u>	15
<u>Biscotti</u>	35
<u>Bloom</u>	27
<u>Blueberry</u>	23
<u>Buttermilk</u>	32
C	
<u>Cantaloupe</u>	28
<u>Canvas</u>	20

<u>Caramel</u>	19
<u>Carrot</u>	31
<u>Cascade</u>	20
<u>Charcoal</u>	3
<u>Cider</u>	32
<u>Clary</u>	18
<u>Clay</u>	36
<u>Cloud</u>	3
<u>Coal</u>	36
<u>Coin</u>	7
<u>Crepe</u>	29
<u>Currant</u>	22

D	
<u>Daffodil</u>	17
<u>Denim</u>	11
<u>Dijon</u>	31
<u>Dusk</u>	9
<u>Dusty</u>	27

E	
<u>Eggplant</u>	24

F	
<u>Fawn</u>	35
<u>Fern</u>	19
<u>Flaxen</u>	37
<u>Flint</u>	4
<u>Frost</u>	2
G	
<u>Ginger</u>	33
<u>Glacier</u>	8
<u>Graphite</u>	7
<u>Gravel</u>	36
<u>Grit</u>	5

H	
<u>Haze</u>	25
<u>Honey</u>	32

I	
<u>Ice</u>	2
<u>Installation</u>	41-42
<u>Iris</u>	23
<u>Iron</u>	4

J	
<u>Jam</u>	30
<u>Juniper</u>	16
L	
<u>Lace</u>	23
<u>Lapis</u>	10
<u>Latte</u>	35
<u>Lavender</u>	25
<u>Lead</u>	7
<u>Leather</u>	38
<u>Lemon</u>	31
<u>Lilac</u>	27
<u>Linen</u>	32

M	
<u>Mahogany</u>	36
<u>Mauve</u>	24
<u>Metallic Test Results</u>	51
<u>Mint</u>	15
<u>Mist</u>	6
<u>Mulberry</u>	23

O	
<u>Oasis</u>	14
<u>Oat</u>	31
<u>Ocean</u>	12
<u>Olive</u>	19
<u>Oslo</u>	11

P	
<u>Pansy</u>	20
<u>Parakeet</u>	16
<u>Parchment</u>	35
<u>Peach</u>	28
<u>Peacock</u>	12
<u>Pear</u>	17
<u>Pebble</u>	37
<u>Petal</u>	28
<u>Pickle</u>	16
<u>Pine</u>	16
<u>Pistachio</u>	19
<u>Plum</u>	26
<u>Porcelain</u>	6
<u>Pumice</u>	3

R	
<u>Rain</u>	14
<u>Rasin</u>	24
<u>Recycled Glass</u>	39-40
<u>Recycled Test Results</u>	47-50
<u>River</u>	11
<u>Rose</u>	28
<u>Rosewood</u>	34
<u>Russet</u>	22
<u>Rust</u>	33
S	
<u>Sage</u>	15
<u>Salmon</u>	27
<u>Salt</u>	2
<u>Sapphire</u>	13
<u>Scarlet</u>	29
<u>Seaweed</u>	15
<u>Setting Systems</u>	43-46
<u>Shadow</u>	4
<u>Shore</u>	8
<u>Sky</u>	9
<u>Slate</u>	12
<u>Smoke</u>	3

INDEX

Snow 2

Spice 34

Steel 5

T

Teal 12

Thyme 20

Twilight 4

T-W

Velvet 24

Wisteria 21

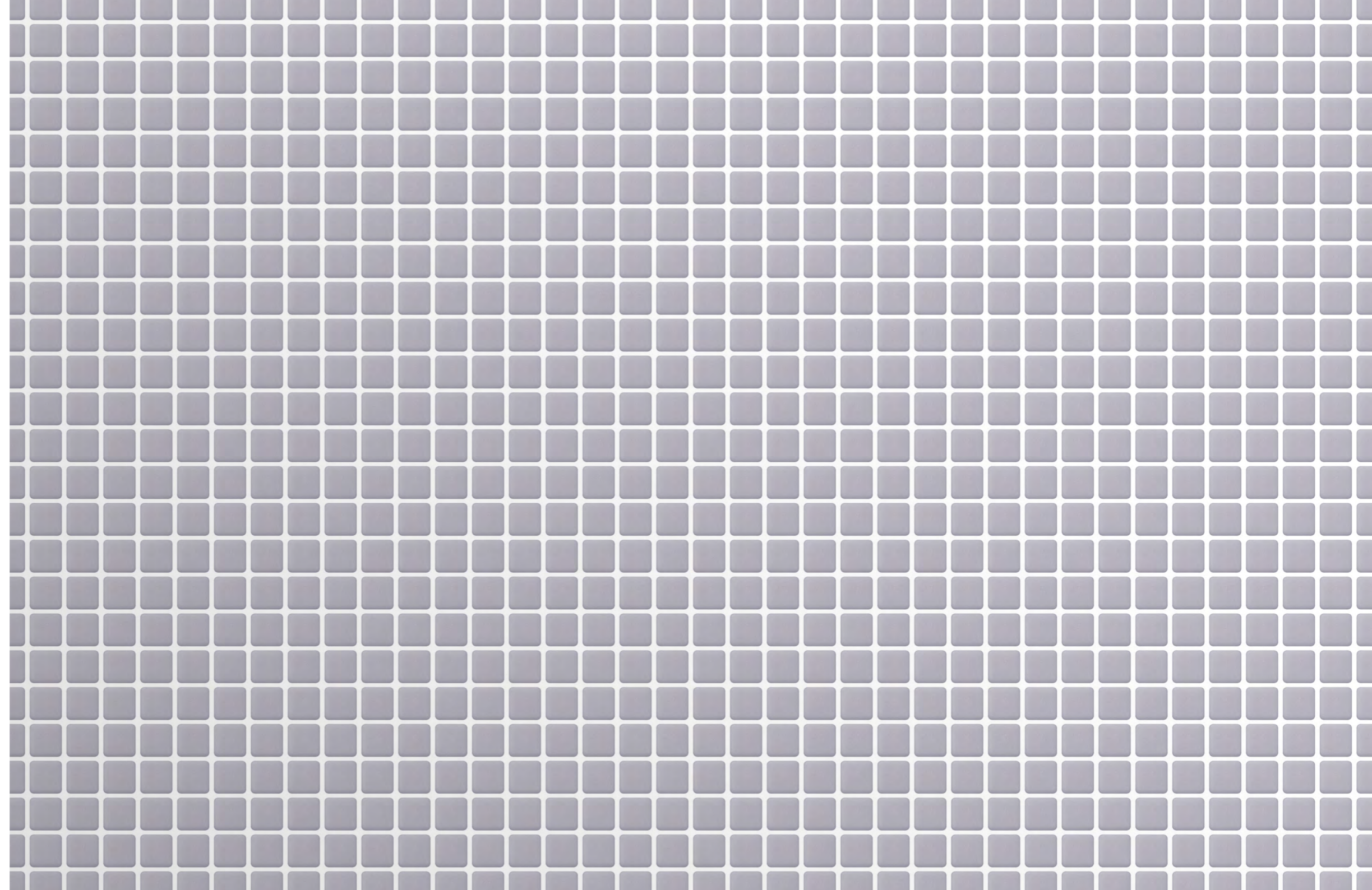

Ginger



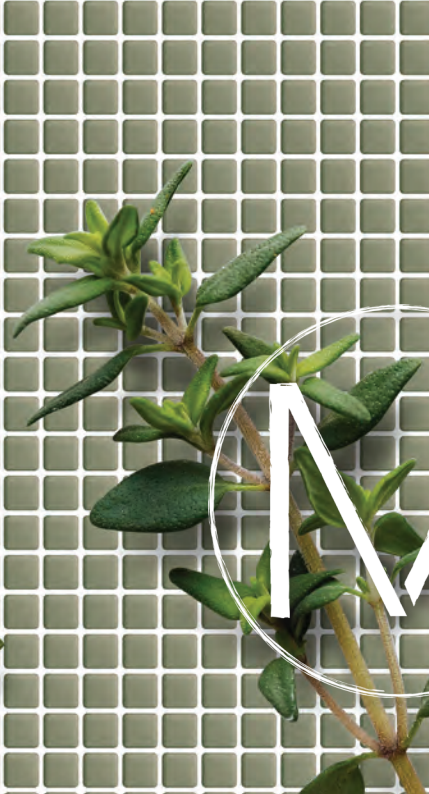
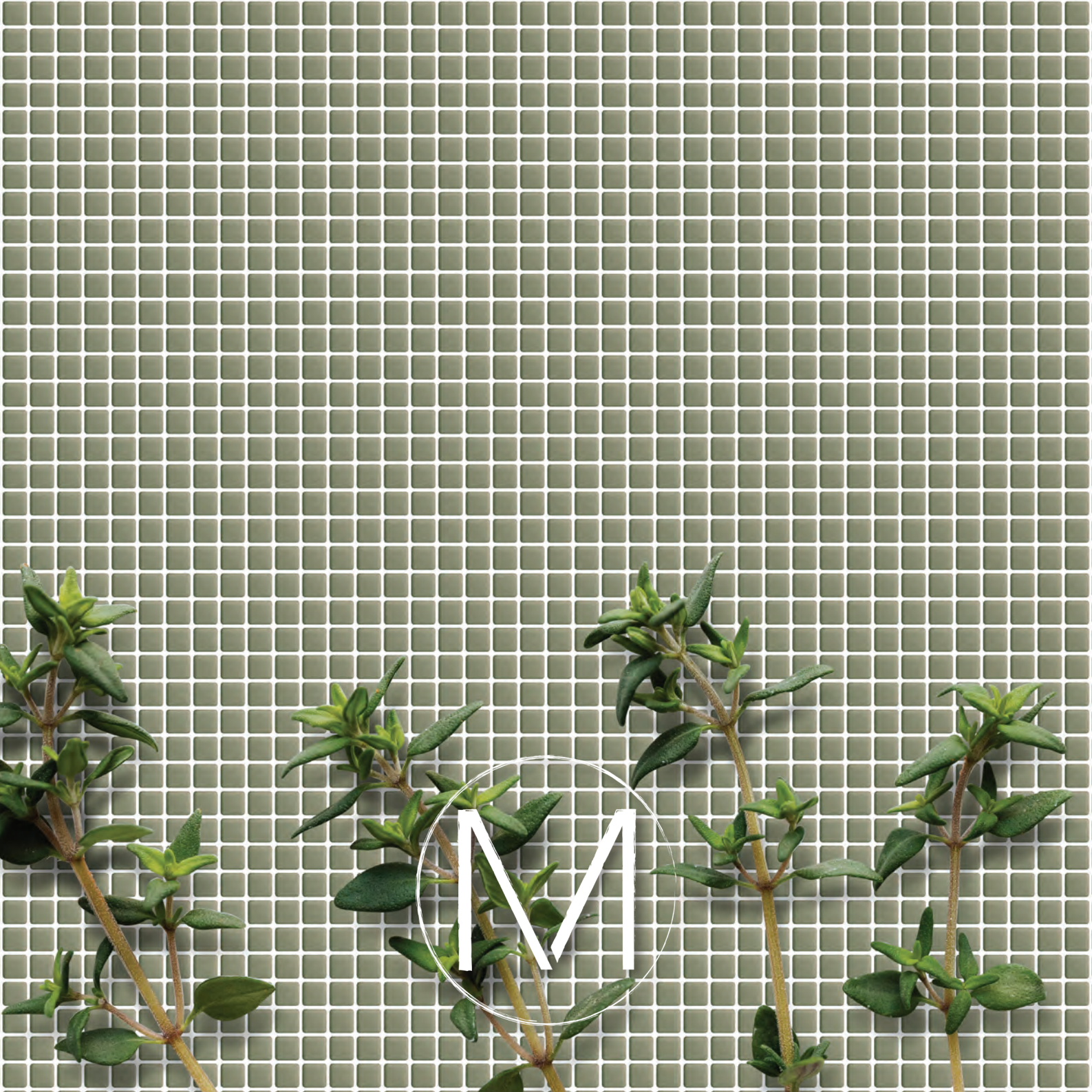

MM

